

Sample Style Configuration Conversion

	BE1-CDS220	BE1-11t	
5 amp Phase with 5 amp Ground	E	6	5 amp Phase
No Option	0	D	5 amp Ground
8 Inputs, 6 Outputs, 1 Alarm	E	2	125/250 PS
No Option	N	M	Modbus over 485
No Option	0	0	No Ethernet
125/250 Vac/dc PS	Z	J	J Case
Six Button HMI with LCD	Y	1	Standard I/O, N.O. Alarm
Modbus over 485	1	P	Current Differential
None	N	0	Copper Ethernet
No Cover	0	E	Option 3, None
Horizontal Panel Mount	H	0	Option 2, None
		00	Latest Firmware

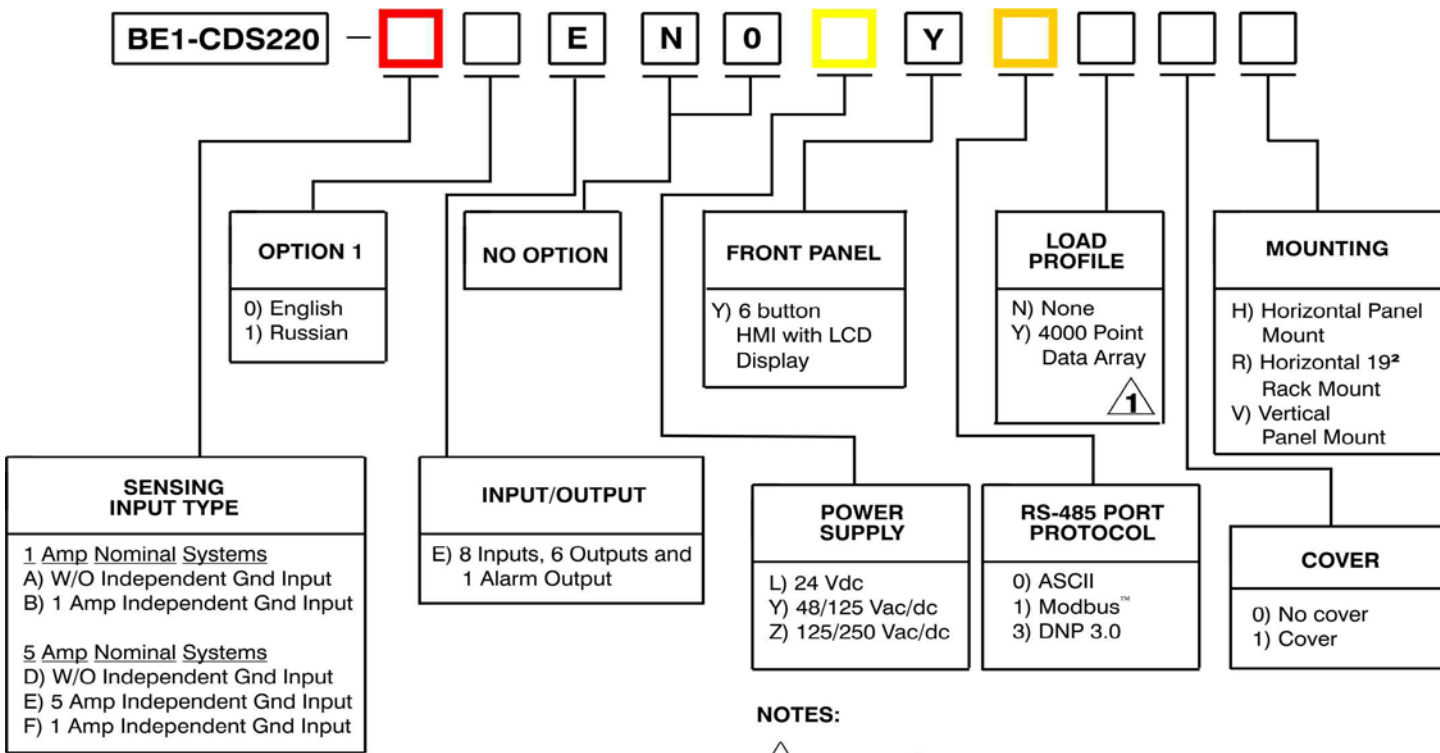

NOTES:

Doubles SER and oscillography memory.

