



Overview

The DECS-450 is a microprocessor based, high performance, extremely reliable excitation controller for positive and positive/negative forcing excitation systems. It supplies control voltage to an external bridge, which supplies dc energy to the main or exciter field of a synchronous machine, making it compatible with any size machine. The DECS-450 comes in many configurations to satisfy specific requirements and redundancy needs. Basler offers customized and standard solutions to fit a wide variety of applications.

Features

- Five control modes with autotracking between modes: AVR, FCR, FVR, var, and PF
- Redundancy options including dual controllers
- 0.10% voltage regulation accuracy
- Paralleling provisions: network load sharing over Ethernet, reactive droop, line drop, and cross-current compensation
- Integrated generator protection (24, 25, 27, 59, 810/U, 32R, 40Q), Field overvoltage, field overcurrent, field overtemperature, and exciter diode monitoring
- Configurable protection expands the protection package, allowing the user to customize protection elements for any sensed parameter
- Limiters include overexcitation, underexcitation, stator current, var and underfrequency or V/Hz
- Auto tuning feature with two PID settings groups (Patent: US 2009/0195224 A1)
- Optional integrated Power System Stabilizer (PSS), IEEE Std. 421.5 type PSS2A/2B/2C
- BESTlogic™ Plus programmable logic is easy to configure and verify
- Integrated autosynchronizer (standard)
- Backward compatible with DECS-400 controllers
 - Installation: Same footprint as DECS-400
 - Wiring: A transition plate (optional) adapts DECS-450 terminals to match DECS-400 terminal positions.
 - Settings: Automatic PID/gain conversion from DECS-400 to DECS-450
 - Logic: Predefined logic scheme to mimic DECS-400 behavior
- Trending, oscillography, and sequence of events recording
- Digital I/O: 14 programmable inputs, 11 programmable outputs, and 1 Form-C output dedicated to watchdog function
- Four analog meter driver outputs
- Expandable I/O via CAN bus communications
 - AEM-2020: Adds 8 analog inputs, 8 RTD inputs, 2 thermocouple inputs, and 4 analog outputs
 - CEM-2020: Adds 10 digital inputs and 24 digital outputs

Benefits

- With its high levels of flexibility and reliability, the DECS-450 is suitable for virtually any synchronous machine.
- Reduce your setup time with Basler's intuitive BESTCOMSPPlus® software that simplifies complex setup with simple drag-and-drop programmable logic (BESTlogic™ Plus), visual real-time strip chart capabilities, and cutting edge auto PID selection capabilities.
- The revolutionary auto tuning function automatically establishes optimum PID and gain settings, taking the guesswork out of system setup, reducing commissioning time and cost while maximizing overall system performance (Patent: US 2009/0195224 A1).
- Avoid costly generator damage and improve overall system stability with an optional integrated PSS that utilizes the "integral of accelerating power" to safely dampen local mode, inter-area, and inter-unit power oscillations.

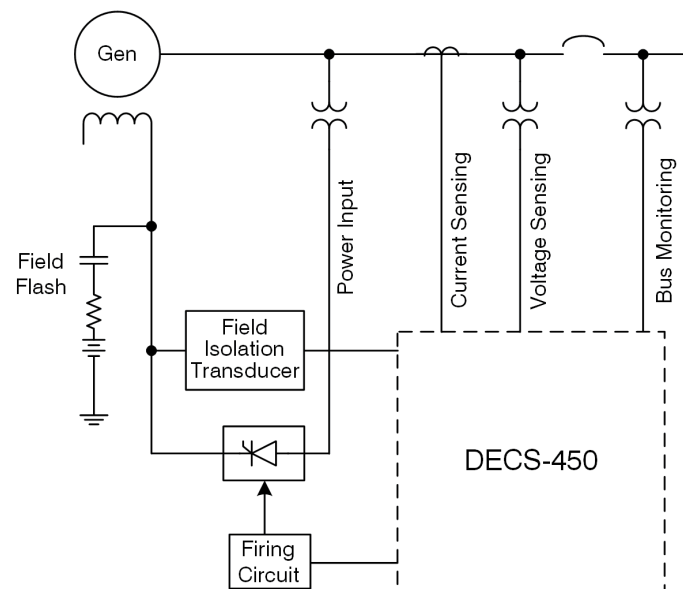

Figure 1 - DECS-450 Connection Diagram for a Typical Application

Specifications

Power Supply

Style XLXXXXX:	24/48 Vdc (nominal) 16 to 60 Vdc
Style XCXXXXX:	125 Vdc/120 Vac (nominal) 90 to 150 Vdc, 82 to 132 Vac, 50/60 Hz
Burden:	50 VA or 35 W

Agency/Certification

UL 6200:2019 recognized, CE UKCA EMC, LVD, and RoHS compliant, China RoHS compliant, and American Bureau of Shipping (ABS) recognized

Generator and Bus Voltage Sensing

Configuration:	1-phase or 3-phase
Nominal:	100/120 Vac, $\pm 10\%$, 50/60 Hz 200/240 Vac, $\pm 10\%$, 50/60 Hz
Burden:	<1 VA per phase

Generator Current Sensing

Configuration:	1-phase or 3-phase with separate input for cross-current compensation
Nominal:	1 Aac or 5 Aac, 50/60 Hz
Burden, 1 Aac CT:	<1 VA
Burden, 5 Aac CT:	<1 VA

Communication

USB:	USB type B
RS-232:	Optional external tracking
RS-485:	Modbus® RTU protocol
CAN Bus:	One port for peripherals, One port for expansion modules
Ethernet:	100BASE-TX or 100BASE-FX, Modbus TCP
Expansion Port:	Optional Profibus protocol

Regulation Accuracy

AVR Mode:	$\pm 0.10\%$
FCR Mode:	$\pm 1.0\%$
FVR Mode:	$\pm 1.0\%$
Var Mode:	$\pm 2.0\%$
Power Factor Mode:	± 0.02 pu

For complete specifications, download the instruction manual at www.basler.com.

Related Products

DECS-2100 Digital Excitation Control System

An extremely powerful, flexible excitation system that precisely controls, protects, and monitors synchronous generators and motors.

BE1-FLEX Protection, Automation and Control System

Designed to be configurable for nearly any Power System Application.

AEM-2020 Analog Expansion Module

Provides additional metering and control with external peripherals through analog I/O.

CEM-2020 Contact Expansion Module

Provides additional contact I/O for large or complex logic schemes in 12/24 V applications.

CEM-125 Contact Expansion Module

Provides additional contact I/O for large or complex logic schemes in 125 V applications.

DECS-250 Digital Excitation Control System

Provides precise voltage, var and Power Factor regulation, and exceptional system response, plus generator and motor protection.

DECS-250E Digital Excitation Control System

Accurate and reliable regulation, control, and protection, in a compact enclosure, for synchronous motors or generators. Three models supply 50, 100, or 200 Adc of continuous excitation current.

DECS-250N Digital Excitation Control System

Provides precise voltage, var and Power Factor regulation, and exceptional system response with negative field-forcing capabilities, plus generator and motor protection.

IDP-801 Interactive Display Panel

A 7.5" (191 mm) Human Machine Interface to view generator system parameters locally or remotely.

IDP-1201 Interactive Display Panel

A 12.1" (307 mm) Human Machine Interface to view generator system parameters locally and remotely.

SGC-250 Synchronous Generator Controller

A prepackaged solution for applications requiring single or dual DECS-250 controllers.

SGC-250N Synchronous Generator Controller

A prepackaged solution for applications requiring single or dual DECS-250N controllers.

SMC-250 Synchronous Motor Controller

Combines the DECS-250 Digital Excitation Control System and the BE1-11m Motor Protection System (prewired, configured, and tested) as a complete unit for easy installation.

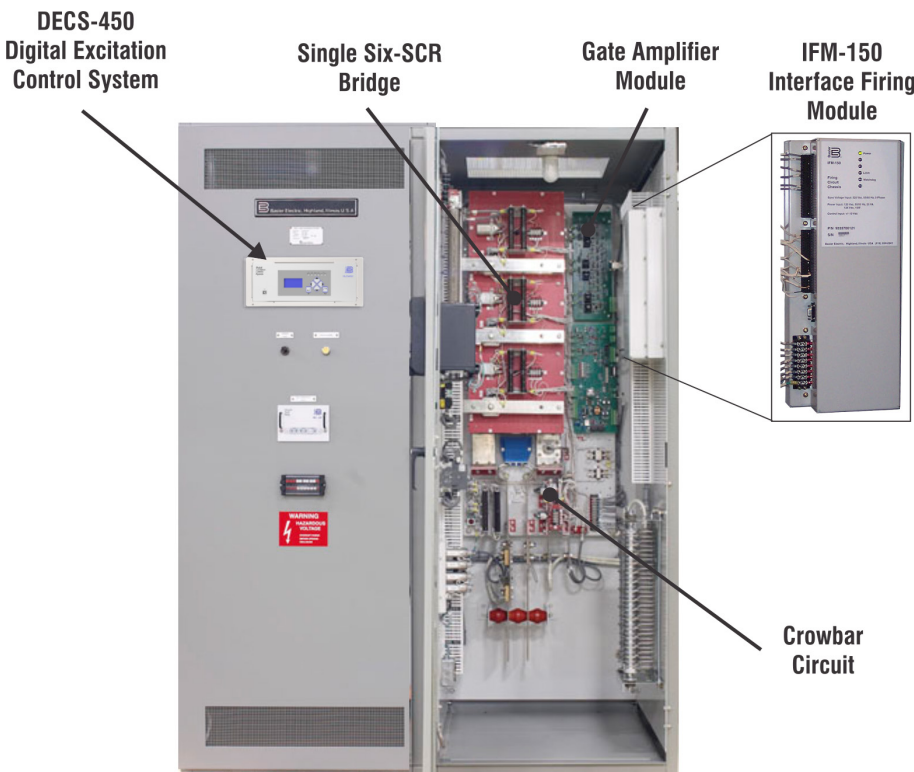

Figure 2 - Typical DECS-450 with Single Rectifier Bridge

Custom Solutions

The specifications listed above are for a typical application, however, DECS-450 Digital Excitation Control Systems are extremely versatile. Contact Basler Electric to begin designing a DECS-450 excitation system to meet the requirements of your specific application.