



Overview

The BE1-700V is a compact, economical, multifunction protective relay for multiple applications including bus, feeder, generator/motor, and cogeneration applications.

Features

- Proven algorithms based on more than 50 years of relaying experience and more than 30 years of reliable digital relaying design.
- One relay for most applications.
- All of the advantages of a fully numeric product in an economical "voltage only" protection package.
- Oscillography, Sequence of Events, and Metering are added when single function voltage relays are replaced with the BE1-700V.
- Zero-sequence voltage (3V0) used to detect single-phase ground faults on high resistance or ungrounded systems can be calculated based on the applied three-phase four-wire sensing voltage, or applied from a separate zero sequence source (optional VX input).
- Optional four-shot recloser, including a pilot initiate path and auxiliary voltage input, replaces existing network (transmission, subtransmission) automatic reclosing schemes.
- Optional configuration via Ethernet with BESTCOMSPPlus®.
- Communications ports: one front USB-C, one rear RS-485, one rear IRIG port, and one rear Ethernet port.
- Communications protocols: Modbus®/TCP, Modbus®/RTU, and BESTCOMSPPlus®.
- Signed firmware ensuring authenticity.

Benefits

- Cost effective, high performance voltage-only multifunction relay.
- BESTCOMSPPlus® software, provided free of charge, makes it easy to enter protection settings with confidence with its intuitive settings, built-in error checking, and summary screens.
- Complex protection is easy to configure and understand with BESTlogic™ Plus. User programmable variable and switch names make these relays completely self-documenting.
- Easily navigate settings and metering with the intuitive HMI menu and large LCD display.
- Programmable LCD eliminates the need for additional meters and control switches.
- Compact design requires minimal panel space.

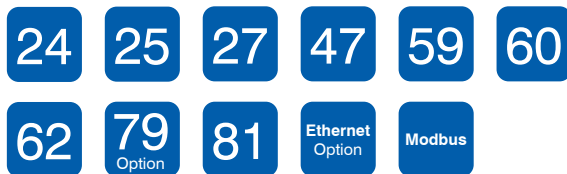

Figure 1 - BE1-700V Device Functions

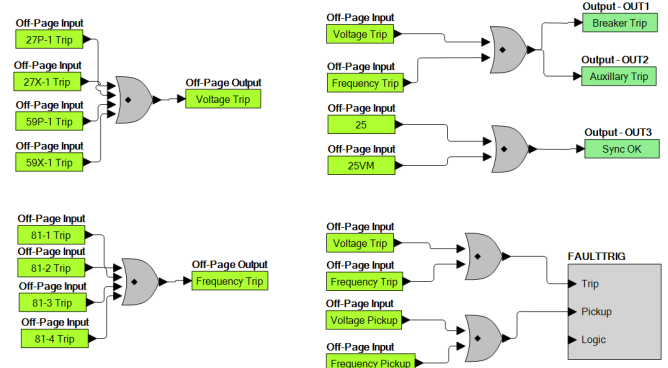

Figure 2 - BESTlogic™ Plus Programmable Logic

Specifications

Power Supply

Option 1:	48 Vdc	35 to 150 Vdc range
Option 2:	125 Vac	90 to 270 Vac range
	125 Vdc	90 to 300 Vdc range
Option 3:	24 Vdc	17 to 32 Vdc range*
Option 4:	250 Vac	90 to 270 Vac range
	250 Vdc	90 to 300 Vdc range
Option 5†:	125 Vac	55 to 135 Vac range
	125 Vdc	35 to 150 Vdc range

* (as low as 8 Vdc for momentary dips)

† (extended holdup option)

Burden: 8 W continuous, 11 W max with all outputs energized

Phase AC Voltage Inputs

Continuous:	300 V, L-L
One Second:	600 V, L-L (3-wire)
	600 V, L-N (4-wire)
Burden:	<1 VA at 300 Vac

Auxiliary AC Voltage Inputs

Continuous:	150 V, L-L
Fault:	360 V, L-L
One Second:	600 V, L-N
Burden:	< 1 VA at 150 Vac

Analog to Digital Converters

Sampling Rate: 32 samples per cycle

Output Contacts

Make and Carry: 30 A (0.2 s)
 Continuous: 7 A
 Break: 0.3 Adc (L/R=0.04) at 125/250 Vdc

Communication

USB-C: BESTCOMSPPlus® access
 RS-485: Terminals A, B, C
 300 - 19200 baud rate
 Modbus®
 Ethernet: 10/100BaseT, RJ-45 connector
 Modbus TCP protocol and BESTCOMSPPlus® access

Isolation

Meets IEC 255-5 and exceeds IEEE C37-90

Surge Withstand Capability (SWC)

Oscillatory and fast transient qualified to IEEE C37.90.1, Standard Surge Withstand Capability (SWC) Tests for Protective Relays and Relay Systems

Electrostatic Discharge (ESD)

IEEE C37.90.3, Standard Electrostatic Discharge Test for Protective Relays

Radio Frequency Interference (RFI)

Qualified to IEEE C37.90.2, Standard Withstand Capability of Relay Systems to Radiated Electromagnetic Interference from Transceivers

Environmental

Operating Temp: -40°C to 70°C (-40°F to 158°F)
 Storage Temp: -40°C to 70°C (-40°F to 158°F)
 Shock: IEC 255-21-2, Class 1
 Vibration: IEC 255-21-1, Class 1
 Seismic: IEC 255-21-3, Class 1
 Humidity: IEC 68-2-38

Agency/Certifications

UL recognized.
 CE and UKCA compliant.
 China RoHS compliant.

Physical

Weight: 4.33 lb (1.96 kg)
 Dimensions (WxHxD):
 10.5 x 4.46 x 7.81 inches (behind panel)
 (266.7 x 113.3 x 198.4 mm)

For complete specifications, download the instruction manual at www.basler.com.

Style Chart

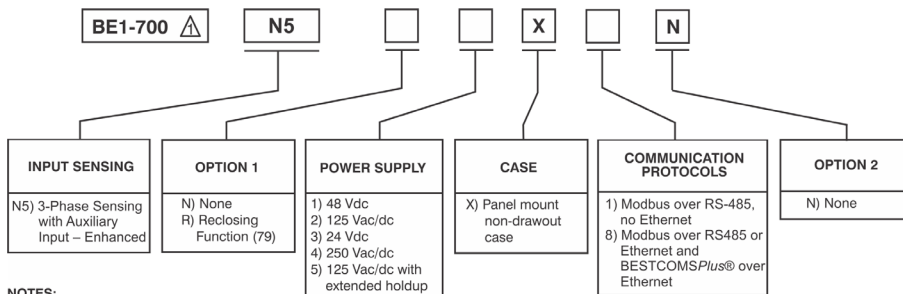

NOTES:
 ⚠ Order Confirmations will show BE1-700, not BE1-700V.

Related Products

BE1-FLEX Protection, Automation and Control System

Designed to be configurable for nearly any Power System Application.

Accessories

Cases, Covers, Connectors, Mounting, Batteries, and Miscellaneous

Designed for adaptive customization with your protective device.