

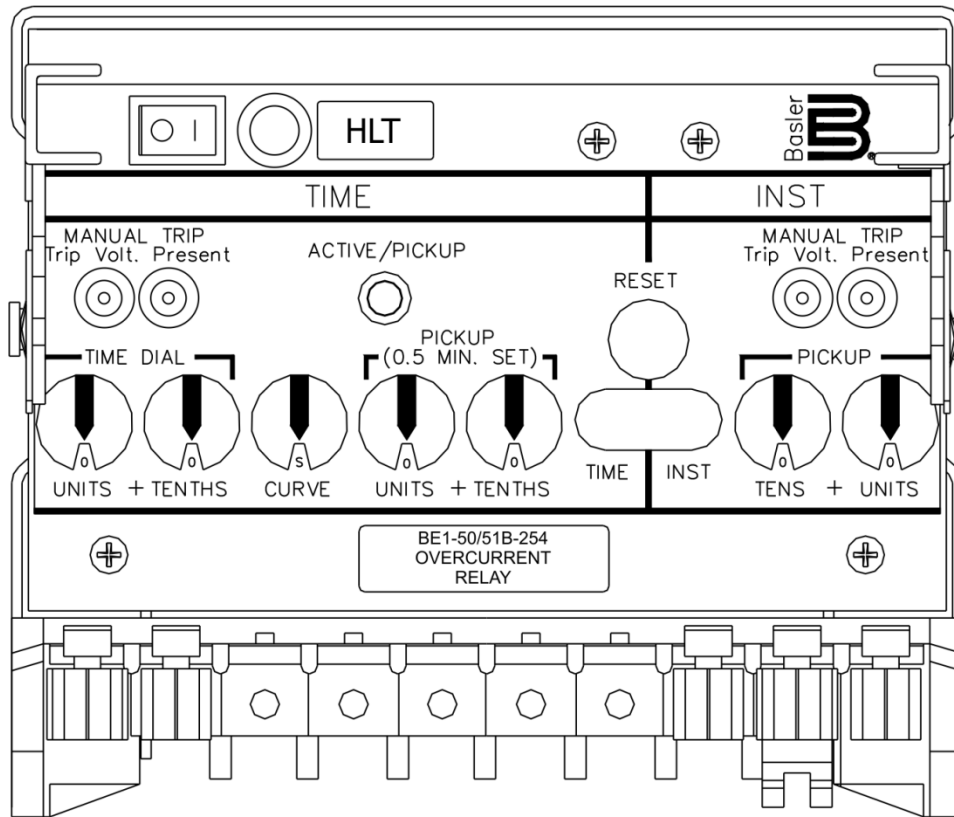



# BE1-50/51B-254

## Overcurrent Relay

*Instruction Manual*



P0079-84

 **WARNING:** California's Proposition 65 requires special warnings for products that may contain chemicals known to the state of California to cause cancer, birth defects or other reproductive harm. Please note that by posting this Proposition 65 warning, we are notifying you that one or more of the Proposition 65 listed chemicals may be present in products we sell to you. For more information about the specific chemicals found in this product, please visit <https://www.basler.com/Prop65>.

# Preface

This instruction manual provides information about the installation and operation of the BE1-50/51B-254. To accomplish this, the following information is provided:

- General information and specifications
- Controls and indicators
- Functional description
- Installation and maintenance
- Testing

## ***Conventions Used in this Manual***

---

Important safety and procedural information is emphasized and presented in this manual through warning, caution, and note boxes. Each type is illustrated and defined as follows.

### **Warning!**

Warning boxes call attention to conditions or actions that may cause personal injury or death.

### **Caution**

Caution boxes call attention to operating conditions that may lead to equipment or property damage.

### **Note**

Note boxes emphasize important information pertaining to installation or operation.



12570 State Route 143  
Highland IL 62249-1074 USA

[www.basler.com](http://www.basler.com)

[info@basler.com](mailto:info@basler.com)

Tel: +1 618.654.2341

Fax: +1 618.654.2351

© 2026 by Basler Electric

All rights reserved

First printing: March 2016

### Warning!

READ THIS MANUAL. Read this manual before installing, operating, or maintaining this equipment. Note all warnings, cautions, and notes in this manual as well as on the product. Keep this manual with the product for reference. Only qualified personnel should install, operate, or service this system. Failure to follow warning and cautionary labels may result in personal injury or property damage. Exercise caution at all times.

Basler Electric does not assume any responsibility to compliance or noncompliance with national code, local code, or any other applicable code. This manual serves as reference material that must be well understood prior to installation, operation, or maintenance.

For terms of service relating to this product and software, see the *Commercial Terms of Products and Services* document available at [www.basler.com/terms](http://www.basler.com/terms).

This publication contains confidential information of Basler Electric Company, an Illinois corporation. It is loaned for confidential use, subject to return on request, and with the mutual understanding that it will not be used in any manner detrimental to the interests of Basler Electric Company and used strictly for the purpose intended.

It is not the intention of this manual to cover all details and variations in equipment, nor does this manual provide data for every possible contingency regarding installation or operation. The availability and design of all features and options are subject to modification without notice. Over time, improvements and revisions may be made to this publication. Before performing any of the following procedures, contact Basler Electric for the latest revision of this manual.

The English-language version of this manual serves as the only approved manual version.

# Revision History

A historical summary of the changes made to this instruction manual is provided below. Revisions are listed in reverse chronological order.

## Instruction Manual Revision History

Manual Revision and Date	Change
E, April 2026	<ul style="list-style-type: none"> <li>• Minor text edits.</li> </ul>
D, May 2025	<ul style="list-style-type: none"> <li>• Updated China RoHS table.</li> <li>• Added FCC statement.</li> </ul>
C, Nov 2024	<ul style="list-style-type: none"> <li>• Updated manual to reflect changes to main board. Target-operating current selection jumpers were added.</li> <li>• Updated burden data.</li> </ul>
B, Mar 2024	<ul style="list-style-type: none"> <li>• Added China RoHS compliance</li> <li>• Minor text edits</li> </ul>
A1, Apr 2019	<ul style="list-style-type: none"> <li>• Added Prop 65 warning</li> </ul>
A, May 2016	<ul style="list-style-type: none"> <li>• Minor text edits</li> </ul>
—, Mar 2016	<ul style="list-style-type: none"> <li>• Initial release</li> </ul>



# Contents

Introduction .....	1-1
Controls and Indicators .....	2-1
Functional Description.....	3-1
Installation.....	4-1
Testing.....	5-1
Specifications.....	6-1
Time Characteristic Curves .....	7-1



# 1 • Introduction

BE1-50/51B-254 protective relays are direct replacements for ABB (Westinghouse) hereinafter referred to as ABB-type CO relays. They are identical to BE1-50/51B-219 relays, but with the addition of the Hot Line Tag (HLT) feature. The

BE1-50/51B-254 has a 5-ampere current sensing input. Specific relays by catalog number are listed in Table 1-1.

**Table 1-1. ABB Relays Suitable for Direct Replacement**

ABB Catalog Number	Curve Type
CO-2*11*1N	Short Time
CO-5*11*1N	Long Time
CO-6*11*1N	Definite
CO-7*11*1N	Moderately Inverse
CO-8*11*1N	Inverse
CO-9*11*1N	Very Inverse
CO-11*11*1N	Extremely Inverse

\* Any digit covering all pickup ranges and 50-Hz or 60-Hz models.

To replace an existing ABB relay, perform the following steps:

1. Select the desired relay settings on your new BE1-50/51B-254 relay.
2. Remove the existing ABB relay cradle.
3. Insert the new relay cradle.
4. Close the knife-blade switches.
5. Install the new Basler Electric cover and secure with the captive thumbnut.

Basler Electric BE1-50/51B-254 protective relays are self-powered, microprocessor-based, non-directional phase or ground relays that monitor the magnitude of a single-phase ac current to provide accurate instantaneous and time overcurrent protection for 50- or 60-hertz power systems. Each model covers 15 popular time characteristics, a wide range of pickup settings, and field-selectable instantaneous or integrating reset.

## Features

A wide range of pickup settings and front-panel-selectable time characteristics permit applications involving coordination with fuses, reclosers, cold-load pickup, motor starting, and fixed-time requirements. Also, an integrating reset function is available to simulate the disk reset of electromechanical relays.

BE1-50/51B-254 overcurrent relays have the following standard features:

- Independent time and instantaneous elements
- Hot Line Tag (HLT)
- A secure method to manually trip the breaker at the relay front panel
- Direct reading front-panel controls
- Minimum pickup setting for safety during installation
- Time characteristics extend to a pickup multiple of 40
- Gravity-latching targets retain indication without power
- Built-in accuracy eliminates internal adjustments
- Minimum transient overreach
- Field-selectable characteristic curve selection similar to either GE-IAC- or ABB-type curves
- Field-selectable instantaneous or integrating reset
- Field-selectable 50- or 60-hertz operation
- Field-selectable 0.0 or 0.1 second fixed instantaneous delay

### Internal Switches

Internal switches provide for selecting system operating frequencies of 50- or 60-hertz, instantaneous element delays of 0.0 or 0.1 second, characteristic curve group selection for either ABB-CO- or GE-IAC-type curves, and instantaneous or integrating reset characteristics. Switch location and description is provided in the *Controls and Indicators* chapter.

### Hot Line Tag

The BE1-50/51B-254 relay's instantaneous (50) element is used to provide the HLT feature and is invoked when the front-panel HLT switch is closed. The HLT switch places the 50 trip contact in parallel with the 51 trip contact. Proper setting of the instantaneous (50) pickup current level in conjunction with the HLT enable switch provides for quickest possible fault detection. A front-panel indicator is illuminated when HLT is active and trip voltage is present. The BE1-50/51B-254 is suitable only for tripping circuits of 125 V nominal.

## **Advantages**

---

BE1-50/51B-254 overcurrent relays have many advantages over other overcurrent relays. The primary advantages are:

- Time characteristics are defined by equations and graphs
- Field-selectable time characteristics
- Very low burden extends the linear range of the CTs
- Self-powered from the sensed current
- Continuous automatic calibration

BE1-50/51B-254 overcurrent relays may be tested without removing the relay from the case. Shorting contacts are provided for all current inputs when the connection plugs or relay chassis is removed from the relay case.

## 2 • Controls and Indicators

Figure 2-1 illustrates the front-panel controls and indicators of the BE1-50/51B-254. Figure 2-2 illustrates the location of switch SW3, J1, and J2. Both illustrations have lettered call-outs that correspond to the control and indicator descriptions provided in Table 2-1.

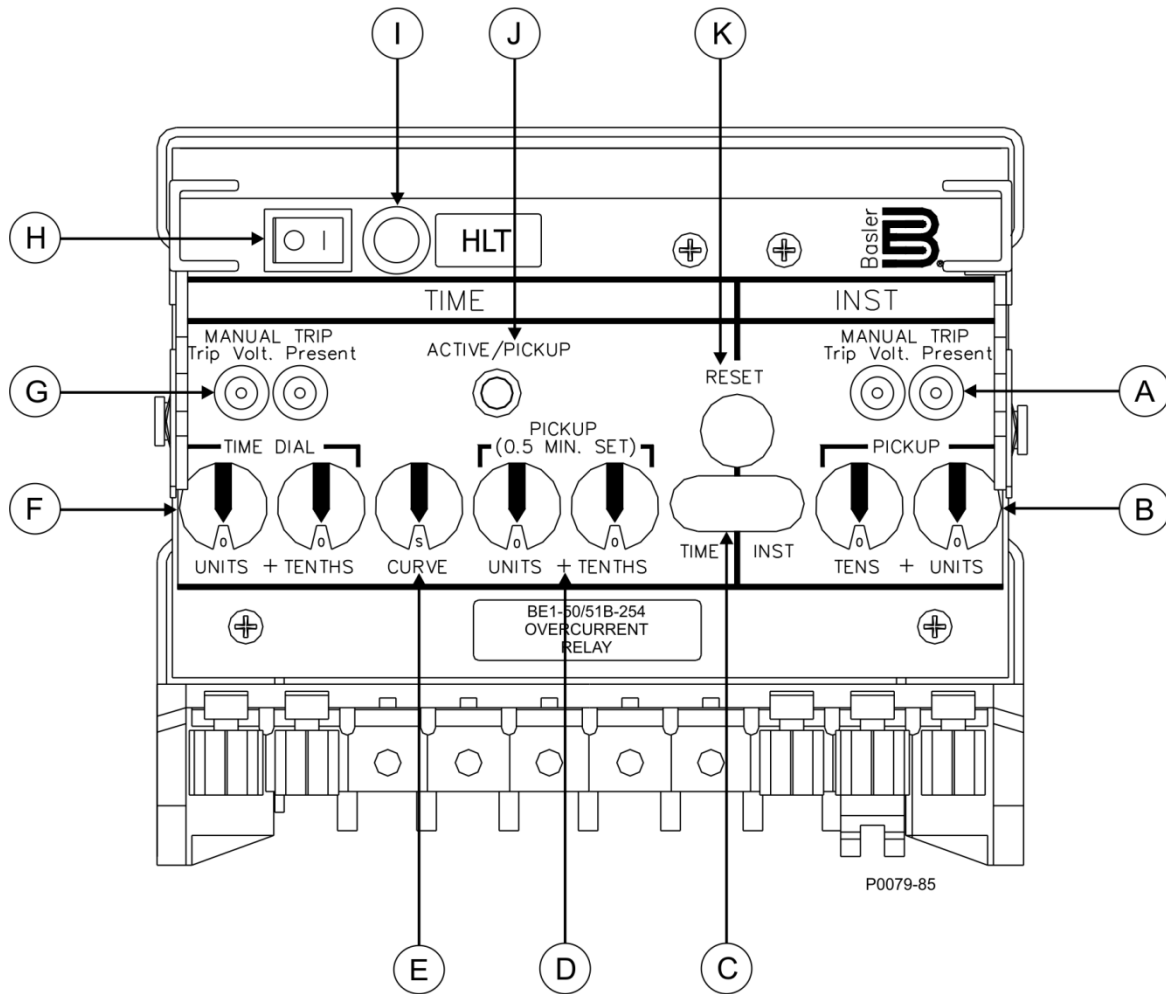

Figure 2-1. Front Panel Controls and Indicators

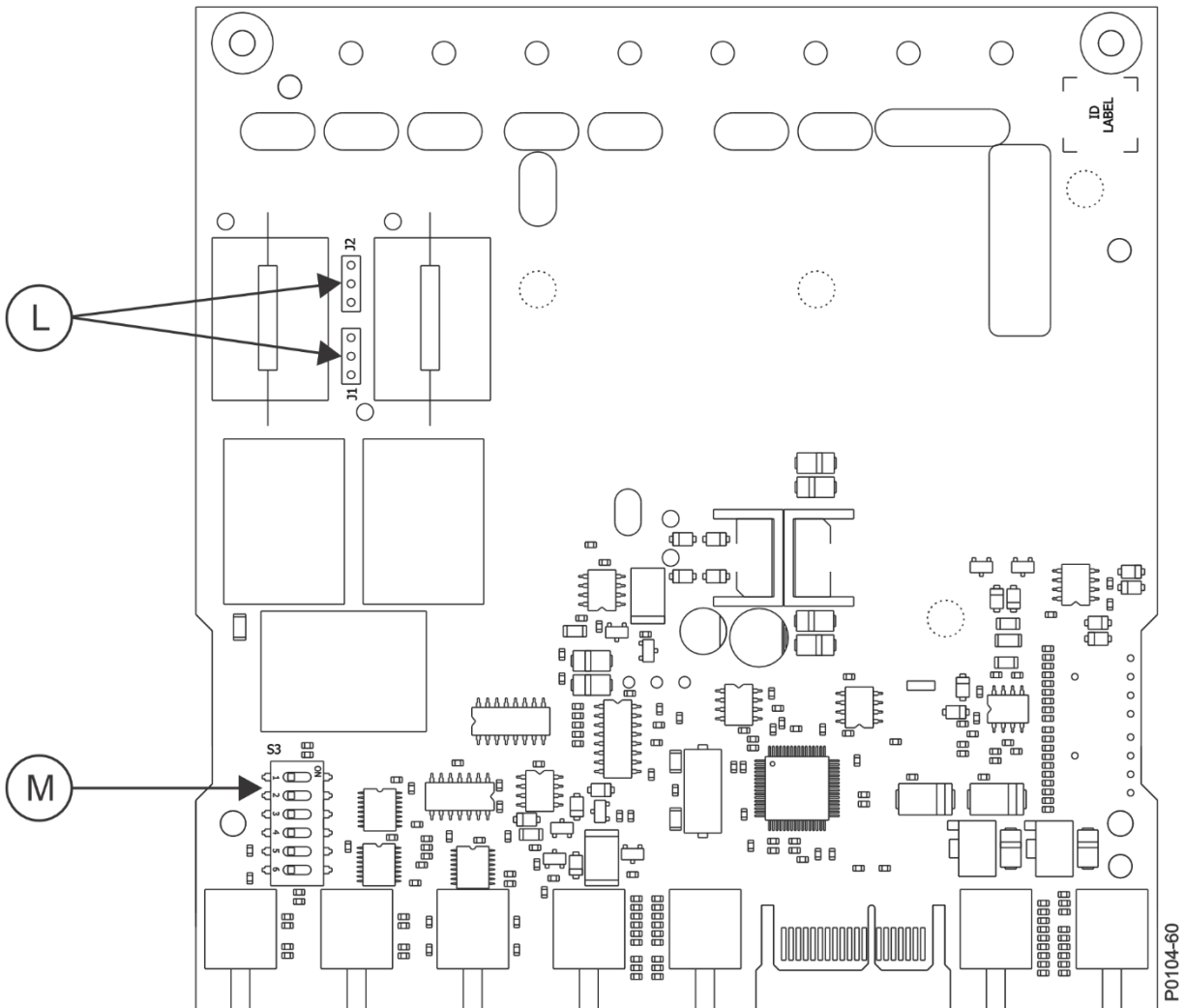

Figure 2-2. Location of Jumpers and Switch

Table 2-1. Controls and Indicators (Refer to Figures 2-1 and 2-2)

Locator	Control or Indicator	Function
A	<b>INST MANUAL TRIP</b> Test Points	When shorted, the test points (jacks) provide a secure means to manually trip the controlled breaker. Jacks accept a standard 0.08-inch diameter phone tip plug.
B	<b>INST PICKUP</b> Selectors	Two switches (TENS and UNITS) to select pickup current in amperes. Changing switch selectors while the relay is in service may cause tripping.
C	Targets	Red target indicators latch when the trip circuit current is greater than 0.2 amperes. One target each for TIME and INST.
D	<b>TIME PICKUP</b> Selectors	Two switches (UNITS and TENTHS) to select pickup current in amperes. Changing switch selectors while the relay is in service may cause tripping.
E	<b>CURVE</b> Selector	Ten-position selector switch to select one of nine inverse functions or one fixed-time function.
F	<b>TIME DIAL</b> Selectors	Two selector switches (UNITS and TENTHS) to select the desired characteristic curve. A setting of 0.0 results in instantaneous operation without any intentional delay. A setting of 9.9

Locator	Control or Indicator	Function
		corresponds to the typical time provided by an electromechanical relay at its maximum dial setting.
<b>G</b>	<b>TIME MANUAL TRIP</b> Test Points	When shorted, the test points provide a secure means to manually trip the controlled breaker. Jacks accept a standard 0.08-inch diameter phone tip plug.
<b>H</b>	Hot Line Tag Switch	This switch enables or disables the Hot Line Tag (HLT) feature. When on (closed), the HLT switch places the 50 trip contact in parallel with the 51 trip contact.
<b>I</b>	<b>HLT</b> Indicator	This red neon indicator illuminates when the Hot Line Tag (HLT) switch is on (closed) and trip circuit voltage is present.
<b>J</b>	<b>ACTIVE/PICKUP</b> LED	This bicolor LED indicates the level of current sensed by the relay. A green LED indicates that the relay is active but not picked up. The LED changes to red when the sensed current exceeds the time overcurrent pickup setting and back to green when the sensed current decreases below 95% of the time overcurrent pickup setting. Note: A minimum of 0.5 A (5A units) or 0.1 A (1A units) is required to light the LED. The LED may not turn green (active) before turning red (picked up) at the 0.5 A pickup setting on 5A units or 0.1 A pickup setting on 1A units.
<b>K</b>	Target <b>RESET</b> Button	Linkage extends through back of front cover to reset both gravity-latched target indicators.
<b>L</b>	<b>Target Operating Current Jumpers</b>	Two user-adjustable jumpers control the range of trip circuit current required to operate the time overcurrent (51) and instantaneous overcurrent (50) target indicators. Jumper J1 sets the minimum current range for the 51 target indicator, and J2 sets the minimum current range for the 50 target indicator. Two jumper positions are possible: across pins 1 and 2 or across pins 2 and 3. Installing a jumper across pins 1 and 2 gives a minimum operating current of 0.9 to 2.25 A. Installing a jumper across pins 2 and 3 gives a minimum operating current of 80 to 200 mA.
<b>M</b>	<b>SW3-1</b>	Selects the system operating frequency. SW3-1 open (OFF) selects 60-Hz operation. SW3-1 closed (ON) selects 50-Hz operation.
	<b>SW3-2</b>	Provides additional time delay for the instantaneous element. Closing switch SW3-2 (ON) provides an additional instantaneous delay of 0.1 second.
	<b>SW3-3</b>	Provides selection of GE-IAC-type curves or ABB-type curves. Closing switch SW3-3 (ON) selects GE-IAC-type curves (refer to the <i>Specifications</i> chapter). Opening switch SW3-3 (OFF) selects ABB-type curves (refer to the <i>Specifications</i> chapter).
	<b>SW3-4</b>	Provides selection of either instantaneous or integrating reset characteristics. Closing SW3-4 (ON) selects integrating reset characteristics. Opening SW3-4 (OFF) selects instantaneous reset characteristics.
	<b>SW3-5</b>	Not used.
	<b>SW3-6</b>	Not used.



## 3 • Functional Description

BE1-50/51B-254 Overcurrent Relays are microprocessor-based non-directional relays that measure ac current to provide secure and reliable instantaneous and time overcurrent protection for power systems.

Figure 3-1 illustrates the functional block diagram.

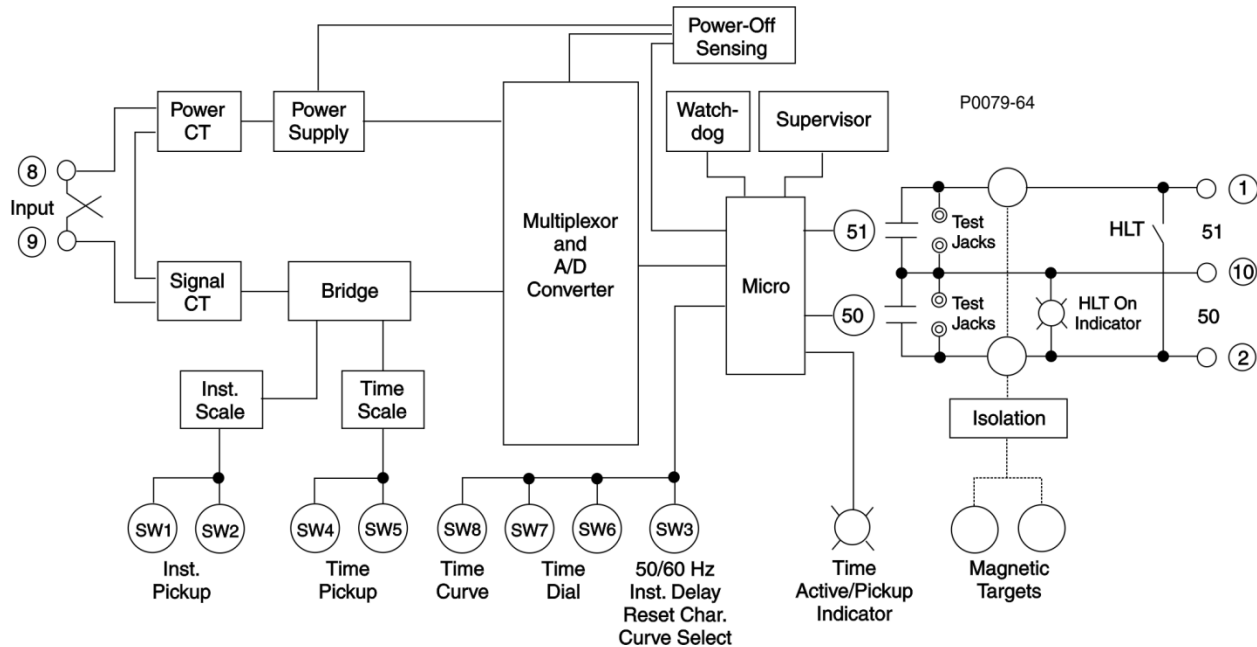

Figure 3-1. Functional Block Diagram

### ***Sensing Input***

Single-phase ac current from system current transformers (CTs) is brought into the Overcurrent Relay at terminals 8 and 9. The input current is applied to internal power and signal CTs.

### ***Power Supply***

Current from the power CT is rectified, filtered, and supplied to all relay internal circuitry for operating power. A precision +5 Vdc supply also serves as a reference for automatic calibration.

### ***Instantaneous Signal***

Current from the signal CT is rectified and applied to the instantaneous scaling resistors controlled by the INST PICKUP selector switches. The analog voltage of the instantaneous input signal developed across the scaling resistors is filtered and applied to the multiplexor (MUX).

### ***Time Signal***

Current from the signal CT is also rectified and applied to the time scaling resistors controlled by the TIME PICKUP selector switches. The analog voltage of the time input signal is also filtered and applied to the multiplexor.

---

## Microprocessor

---

Operating power from the power supply is applied to the microprocessor supervisor circuit. When the microprocessor is active and executing code, the ACTIVE/PICKUP LED is green. When the input current falls below an acceptable level, the supervisor circuit interrupts the microprocessor, halts further operation, and turns OFF the ACTIVE/PICKUP LED. A microprocessor watchdog feature resets the microprocessor program when the program flow is interrupted.

Information from the TIME DIAL selector switches, the TIME CURVE selector switch, and the 50/60 Hz, INST DELAY, and RESET CHAR switches is also applied to the microprocessor. The microprocessor uses these inputs to set the operating parameters.

When the microprocessor is ready for analog information from the multiplexor, microprocessor control signals cause the multiplexor to route the desired input through to the output. The output is converted from an analog value to a digital value and applied to the microprocessor.

The microprocessor performs the program operations based on the inputs and the internal software program. When the sensed current exceeds the TIME PICKUP setting, the ACTIVE/PICKUP LED turns from green to red. TIME contacts (51) are closed in accordance with the time characteristic equation. If the sensed current exceeds the INST PICKUP setting, the INST contacts (50) are closed.

---

## Power-Off Sensing

---

Power-off sensing circuits measure the voltage across a capacitor at power-down and at power-up. These circuits determine how long power has been removed based on the difference voltage and the circuit RC time constant. This provides information for the integrating reset function even when power has been entirely removed.

---

## Outputs

---

### *Instantaneous and Timed*

System circuit breakers controlled by the output contacts can be manually tripped by applying a short across the TIME or INST MANUAL TRIP front-panel test points. Current flow in the trip circuit is indicated by the operation of the target. The targets will not operate without adequate operating power for the relay.

### **Warning!**

Trip-circuit voltage is present at the front-panel test points. When shorting the test points, use insulated jumpers to avoid contact with these voltages.

---

## Hot Line Tag (HLT)

---

Closure of the front-panel HLT switch places the 50 trip contact in parallel with the 51 trip contact. A front-panel indicator signals when HLT is active. The BE1-50/51B-254 is suitable only for 125 V nominal tripping circuits.

---

## Target Indicators

---

Gravity-latched, manually-reset, current-operated target indicators are provided for the time overcurrent (51) trip output and the instantaneous overcurrent A (50) trip output. The level of trip circuit current required to operate each target is individually controlled by a circuit board jumper. The minimum operating current range can be set for 80 to 200 milliamperes or 0.9 to 2.25 amperes. See Section 2, *Controls and Indicators* for jumper locations and function assignments.

## 4 • Installation

When not shipped as part of a control or switchgear panel, the relays are shipped in sturdy cartons to prevent damage during transit. Immediately upon receipt of a relay, check the model and part number against the requisition and packing list to verify that they agree. Visually inspect the relay for damage that may have occurred during shipment. If there is evidence of damage, immediately file a claim with the carrier and notify the Regional Sales Office, or contact the Sales Representative at Basler Electric, Highland, Illinois.

Proper operation of the relay may be confirmed by performing the operational test procedure in the *Testing* chapter. If the relay won't be installed immediately, store the relay in its original shipping carton in a moisture- and dust-free environment.

### **Factory Settings**

Factory settings for the internal switches of SW3 are as follows:

- SW3-1 — OFF (60-hertz operation).
- SW3-2 — OFF (0.0 additional fixed delay for the instantaneous element)
- SW3-3 — OFF (ABB-type characteristic curves)
- SW3-4 — ON (Integrating reset characteristics)
- SW3-5 — Not used
- SW3-6 — Not used
- J1 pins 2-3 — 50-A minimum target operating current of 80 to 200 mA
- J2 pins 2-3 — 51 minimum target operating current of 80 to 200 mA

### **Installation**

Select the desired relay settings before putting the relay into service. Changing pickup current settings while the relay is in service may cause tripping. Perform the following procedures to install the BE1-50/51B-254 relay:

- Select the desired relay settings on your new BE1-50/51B-254 relay.
- Remove the existing ABB relay cradle.
- Insert the new relay cradle and close the cradle latches locking the relay into the case.

#### **Caution**

Close all BLACK handle switches before closing any RED handle switches. Ensure that the RED handle switches are closed last.

- Close knife-blade switches.
- To install the cover, position the interlocking bracket at the top of the new Basler Electric cover into the mating receptacle at the top of the case. Secure the captive fastener at the bottom of the cover.

## Connections

Typical ac input and dc control connections are shown in Figure 4-1 and Figure 4-2 Refer to the block diagram in the *Functional Description* chapter for relay internal connections.

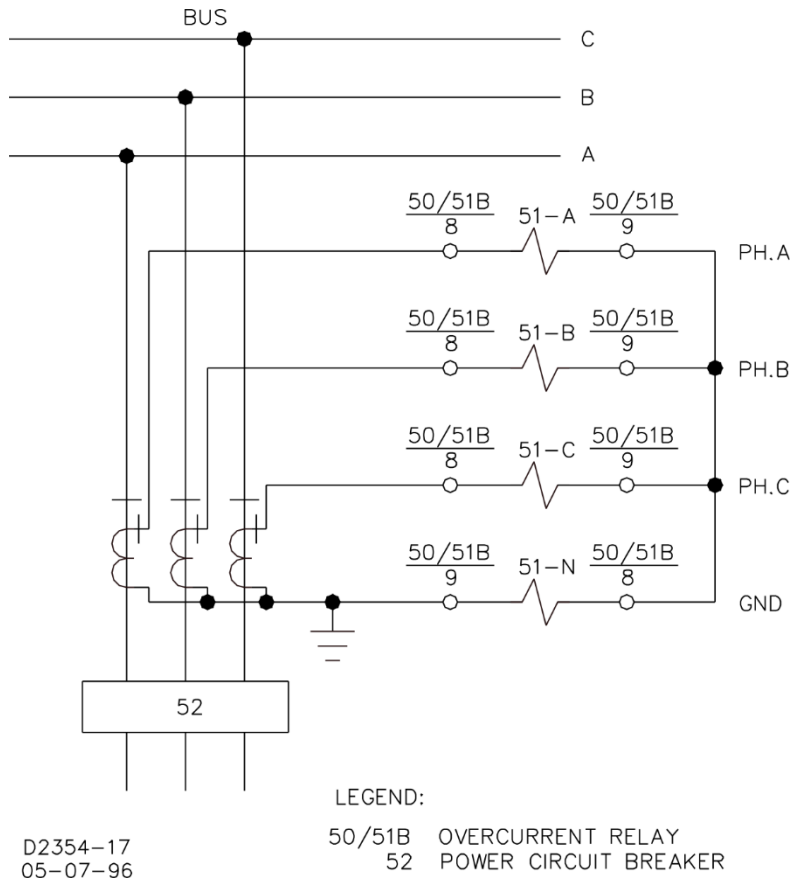

**Figure 4-1. AC Input Connections**

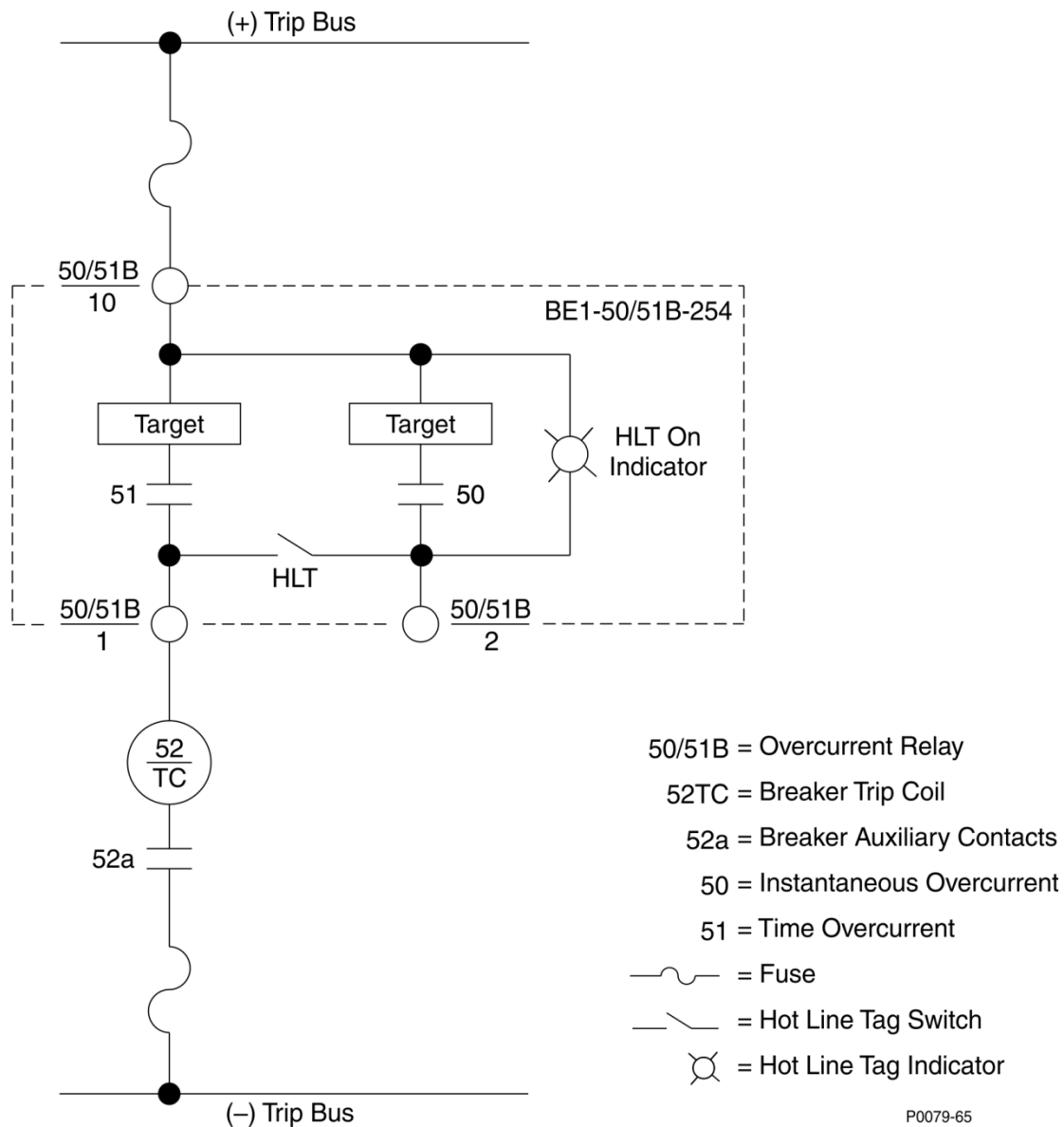

Figure 4-2. DC Control Connections

## Application Coordination

In a typical application coordination scheme, a BE1-50/51B-254 is being used to provide primary protection for a radial distribution feeder. An electromechanical overcurrent relay with extremely inverse timing provides protection for the transformer and bus. To improve coordination with the electromechanical relay, the BE1 relay with integrating reset characteristic has the time characteristic curve E (extremely inverse) selected (SW3-3 set to OFF) and the TIME DIAL set to 2.0. The feeder reclosing relay is set for two reclose attempts at 3 and 15 seconds after the initial trip. If a permanent fault occurs (magnitude ten times pickup), calculate the feeder breaker trip time for each of the three operations. Refer to the *Specifications* chapter for characteristic curve constants.

From the time characteristic curve equation:

$$\begin{aligned}
 T_{\text{Trip}} &= \frac{AD}{M^N - C} + BD + K \\
 &= \frac{7.7624 \times 2}{10^{2.0938} - 1} + (0.02758 \times 2) + 0.028 \\
 &= \frac{15.5248}{124.10806 - 1} + 0.05516 + 0.028 \\
 &= 0.209 \text{ seconds}
 \end{aligned}$$

From the reset characteristic curve equation:

$$\begin{aligned}
 T_{\text{Reset}} &= \frac{RD}{M^2 - 1} \\
 &= \frac{7.75 \times 2}{0^2 - 1} = -15.5 \text{ seconds}
 \end{aligned}$$

$M = 0$  if current goes to zero.

Negative result indicates reset time.

**Results:** Full trip = 0.209 seconds and full reset = 15.5 seconds if current goes to zero.

In Figure 4-3,

$T_A = 0.209$  seconds (relay was at reset).

$T_B = \text{value} < T_A$  because rewind has not gone to zero.

$T_C = \text{value} < T_A$  because rewind has not gone to zero.

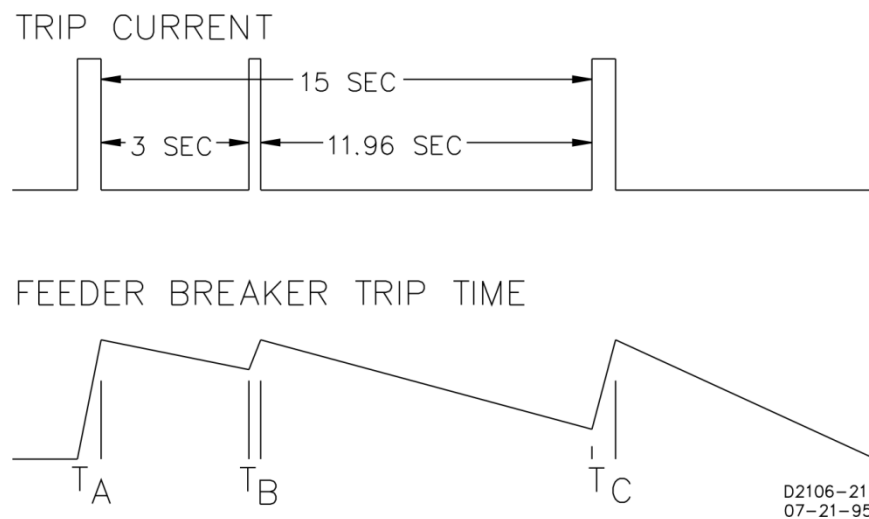

Figure 4-3. Coordination Timing Diagram

Equation for time to trip during rewind (before relay is reset):

$$T_{\text{Trip This Occurrence}} = \frac{(\text{Full Trip})(\text{Rewind Time})}{\text{Full Rewind}}$$

Second Operation:

$$T_B = \frac{(0.209)(3)}{15.5}$$

$$T_B = 0.040 \text{ seconds}$$

Third Operation:

$$T_C = \frac{(0.209)(11.96)}{15.5}$$

$$T_C = 0.161 \text{ seconds}$$

## **Maintenance**

---

BE1-50/51B-254 overcurrent relays require no preventive maintenance. However, periodic checks should be performed according to scheduled practices. A recommended periodic test is provided in the *Testing* chapter. If the relay fails to function properly, contact the Technical Sales Support Department of Basler Electric.

## **Storage**

---

This device contains long-life aluminum electrolytic capacitors. For devices that are not in service (spares in storage), the life of these capacitors can be maximized by energizing the device for 30 minutes once per year.



## 5 • Testing

Dielectric testing, operational testing, and periodic testing are described in the following paragraphs.

### Dielectric Test

In accordance with IEC 255-5 and IEEE C37.90-2005, one-minute dielectric (high potential) tests may be performed as follows:

All circuits to cradle ..... 2,828 Vdc or 2,000 Vac

Input to output circuits ..... 2,828 Vdc or 2,000 Vac

Output contacts are surge protected.

### Operational Test Procedure

The following procedures verify operation of the BE1-50/51B-254 relay. Figure 5-1 and Figure 5-2 are intended primarily as an illustration of the principles involved. Other test setups known to be capable of testing with the stated and implied tolerances (including equipment specifically designed for testing relays) may be used.

#### Test Equipment Required

- Current source with a range from 0 to 20 Aac (sensing input current)
- DC power source (target operation)
- Timer or counter

#### Caution

To ensure proper timing during testing, before each test, remove the current from the unit for R times D seconds (refer to the *Specifications* chapter for R and D definitions).

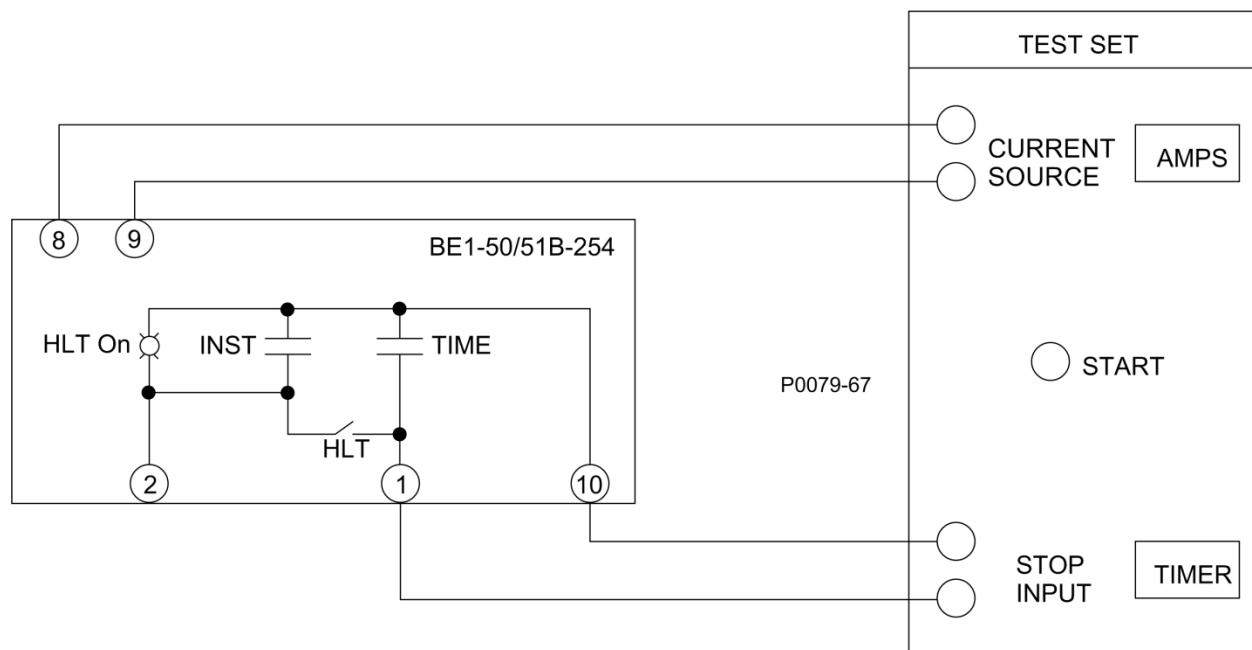

Figure 5-1. Pickup and Timing Test Setup

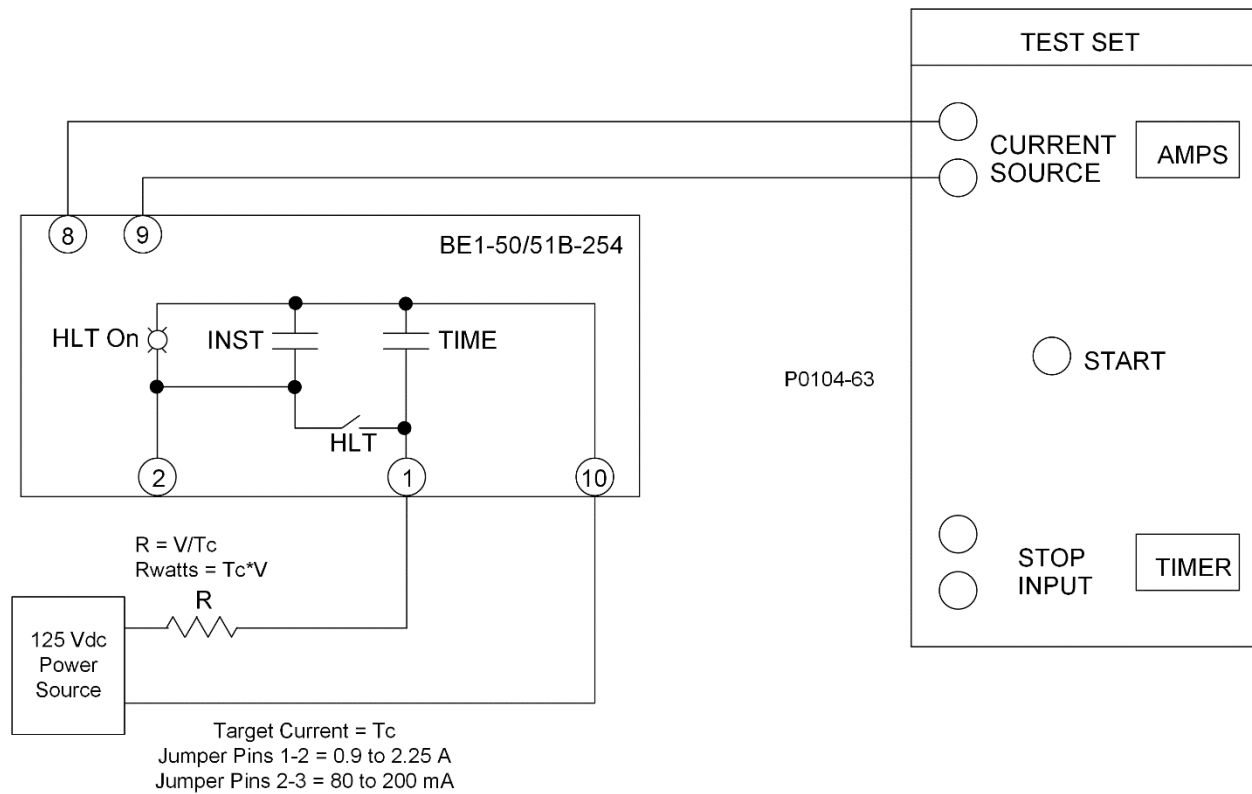

Figure 5-2. Target Operational Test Setup

### Note

When testing TIME overcurrent functions, INST PICKUP settings of 00 will affect the calibration of the TIME functions. TIME PICKUP settings of 00 also affect INST functions.

## Test Procedure

### Time Pickup Test

Perform preliminary setup:

- Connect test setup as shown in Figure 5-1.
- Ensure that SW3 switches are set: SW3-1 for the operating frequency, SW3-2 to OFF, SW3-3 to OFF, and SW3-4 to ON.
- Set TIME DIAL to 0.0.
- Set CURVE to S.
- Set TIME PICKUP to 0.5.
- Set INST PICKUP to 90.
- Open the Hot Line Tag (HLT) switch.

Step 1. Slowly increase current to terminals 8 and 9. PICKUP LED should turn RED at a maximum input current of 0.550 ampere.

Step 2. Decrease input current until PICKUP LED turns GREEN then OFF.

Step 3. Set TIME PICKUP to 2.2.

Step 4. Slowly increase current to terminals 8 and 9. PICKUP LED should change from GREEN to RED at an input current of 2.131 to 2.269 amperes.

Step 5. Decrease input current until PICKUP LED turns OFF.

### INST Pickup Test

Perform preliminary setup:

- Connect test setup as shown in Figure 5-1.
- Ensure that SW3 switches are set: SW3-1 for the operating frequency, SW3-2 to OFF, SW3-3 to OFF, and SW3-4 ON.
- Set TIME DIAL to 0.0.
- Set CURVE to S.
- Set TIME PICKUP to 15.9.
- Set INST PICKUP to 01.
- Close the Hot Line Tag (HLT) switch.

Step 1. Slowly increase current to terminals 8 and 9. INST contacts should close at an input current of 0.955 to 1.045 amperes.

Step 2. Decrease input current until INST output contacts open.

Step 3. Set INST PICKUP to 08.

Step 4. Slowly increase current to terminals 8 and 9. INST contacts should close at an input current of 7.815 to 8.185 amperes.

Step 5. Decrease input current until INST output contacts open.

### Time Dial Test

Perform preliminary setup:

- Connect test setup as shown in Figure 5-1.
- Ensure that SW3 switches are set: SW3-1 for the operating frequency, SW3-2 to OFF, SW3-3 to OFF, and SW3-4 ON.
- Set TIME DIAL to 4.5.
- Set CURVE to S.
- Set TIME PICKUP to 1.0.
- Set INST PICKUP to 90.
- Open the Hot Line Tag (HLT) switch.

Step 1. Prepare to apply 1.5 amperes input current to terminals 8 and 9 and record the elapsed time from when current is applied until TIME output contacts close.

Step 2. Apply the current (step from 0 to 1.5 amperes) and record the elapsed time. Elapsed time should be 1.754 to 2.084 seconds. (This tolerance is greater than  $\pm 2\%$  because it is the accumulation of both pickup and timing tolerances.)

Step 3. Remove input current.

### Target Test

Perform preliminary setup:

- Connect test setup as shown in Figure 5-2.
- Ensure that SW3 switches are set: SW3-1 for the operating frequency, SW3-2 to OFF, SW3-3 to OFF, and SW3-4 ON.
- Set TIME DIAL to 4.5.
- Set CURVE to S.
- Set TIME PICKUP to 1.0.
- Set INST PICKUP to 90.
- Close the Hot Line Tag (HLT) switch.

Step 1. Apply 5 Aac to terminals 8 and 9 to trip the 51 relay output.

Step 2. Slowly increase the power source to provide target current and verify that the Time target operates at the level of current determined by the Target Operating Current Jumpers.

The Target Operating Current Jumpers are located on the circuit board and identified as J1 and J2. J1 sets the minimum current range for the 51 target, and J2 sets the minimum current range for the 50 target. A jumper installed across pins 1 and 2 gives a minimum operating current of 0.9 to 2.25 A. A jumper installed across pins 2 and 3 gives a minimum operating current of 80 to 200 mA.

Step 3. Remove the target and sensing current and reset the target.

Step 4. Set TIME PICKUP to 15.9 and set INST PICKUP to 01.

Step 5. Apply 5 Aac to terminals 8 and 9 to trip the 50 relay output.

Step 6. Remove the target and sensing current and reset the target.

Step 7. Remove input current and reset target.

#### Hot Line Tag (HLT) Test

Perform preliminary setup:

- Connect test setup as shown in Figure 5-2.
- Ensure that SW3 switches are set: SW3-1 for the operating frequency, SW3-2 to OFF, SW3-3 to OFF, and SW3-4 ON.
- Set TIME DIAL to 4.5.
- Set CURVE to S.
- Set TIME PICKUP to 15.9.
- Set INST PICKUP to 01.
- Open the Hot Line Tag (HLT) switch.

Step 1. Set power source to provide a target current of 1.0 A or 100 mA according to J1 and J2 positions.

Step 2. Close the HLT switch and verify that the HLT neon light is illuminated.

Step 3. Apply 5 amperes input current to terminals 5 and 6. Check that the INST target operates.

Step 4. Remove input current and reset targets.

Step 5. Open the HLT switch and verify that the HLT neon light is not illuminated.

Step 6. Apply 5 amperes input current to terminals 5 and 6. Check that the INST target does not operate.

Step 7. Remove input current.

#### Manual Trip Test

Perform preliminary setup:

- Connect test setup as shown in Figure 5-2.
- Ensure that SW3 switches are set: SW3-1 for the operating frequency, SW3-2 to OFF, SW3-3 to OFF, and SW3-4 ON.
- Set TIME DIAL to 4.5.
- Set CURVE to S.
- Set TIME PICKUP to 1.0.
- Set INST PICKUP to 01.
- Close the Hot Line Tag (HLT) switch.

### Warning!

Trip-circuit voltage is present at the front-panel test points. When shorting the test points, use insulated jumpers to avoid contact with these voltages.

Step 1. Set power source to provide a target current of 1.0 A or 100 mA according to J1 and J2 positions.

Step 2. Apply 0.9 ampere input current to terminals 8 and 9. (0.9 ampere provides input power but stays below pickup.)

Step 3. Connect a jumper between TIME MANUAL TRIP test points. Check that TIME target operates.

Step 4. Connect a jumper between INST MANUAL TRIP test points. Check that INST target operates.

Step 5. Reset targets.

### Integrating Reset Test

Perform preliminary setup:

- Connect test setup as shown in Figure 5-1.
- Ensure that SW3 switches are set: SW3-1 for the operating frequency, SW3-2 to OFF, SW3-3 to OFF, and SW3-4 ON.
- Set TIME DIAL to 9.9.
- Set CURVE to V.
- Set TIME PICKUP to 1.0.
- Set INST PICKUP to 90.
- Open the Hot Line Tag (HLT) switch.

Step 1. Set power source to provide a target current of 1.0 ampere.

Step 2. Read all of Step 3 before beginning Step 3.

Step 3. Apply 4.0 amperes input current to terminals 8 and 9. After the unit trips, remove the input current for  $29 \pm 0.25$  seconds, then reapply the 4.0 amperes input current. Record the elapsed time from the re-application of input current to the output retrip.

**Result:** Elapsed time should be  $2.08 \pm 0.4$  seconds.

## **Periodic Tests**

---

### **General**

All relays should be tested periodically to identify and correct any problems that are found.

Single-phase relays such as the BE1-50/51B-254 are normally used in groups of four (three phases and ground) on the protected circuit. This relay scheme allows each unit to be withdrawn one at a time for testing purposes without losing protection. Only three are required at any one time to sense all types of faults on a grounded wye system. Refer to Figures 5-1 and 5-2 for recommended test setups.

### **Periodic Test**

Periodic testing should consist of the following procedures.

Step 1. Verify that the instantaneous pickup is within  $\pm 2\%$  of the value set on the dials. Pickup occurs when the INST output contacts close.

Step 2. Verify that the time pickup is within  $\pm 2\%$  of the value set on the dials. Pickup occurs when the LED turns GREEN then RED.

Step 3. Verify that the time to trip for the curve and time dial settings at a multiple of six is the same as the time given on the characteristic curve. Refer to the *Time Characteristic Curves* chapter for the characteristic curves.

Step 4. Verify that the time to trip for the instantaneous element at a pickup multiple of 2 is not greater than the time given on the instantaneous characteristic curve. Refer to the *Time Characteristic Curves* chapter for the instantaneous characteristic curve.

Step 5. Verify that the targets operate with one ac ampere of trip current in the trip circuits and that they can be reset using the RESET BUTTON.

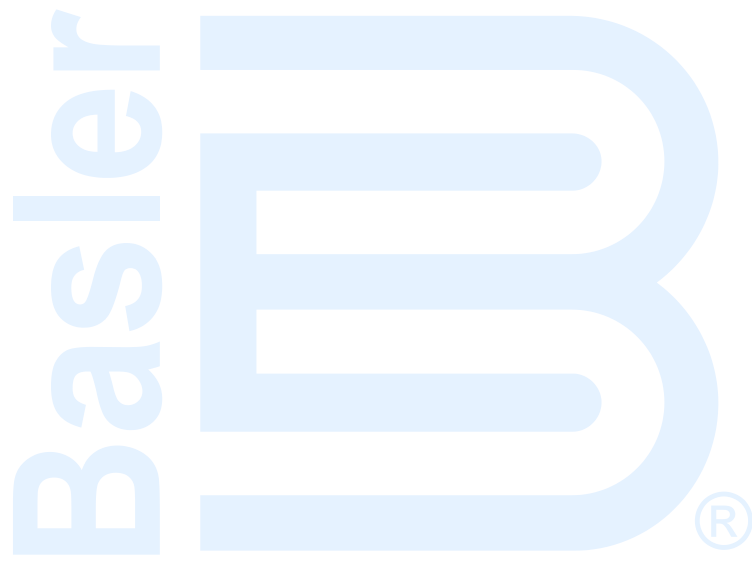

## 6 • Specifications

BE1-50/51B-254 electrical and physical specifications are listed in the following paragraphs.

### ***Operational Specifications***

---

#### **Time Overcurrent (51) Element**

Setting the TIME PICKUP control at the minimum pickup setting (0.5) places the relay in the most sensitive state and may be used as a safety setting.

##### Pickup

Setting Range ..... 0.5 to 15.9 Aac  
 Setting Increment ..... 0.1 Aac  
 Accuracy ..... ±2%, ±25 milliamperes at or above 0.5 ampere setting

##### Dropout

Dropout occurs at 95% of pickup value.

##### Timing Range

0.0 to 9.9 seconds in 0.1 second steps.

##### Timing Accuracy

The timing accuracy is the sum of ±1 cycle and ±2% for the range of 2 to 40 times tap and is for a given measured multiple of tap. The timing accuracy is the sum of ±2 cycles and ±2% for the range of 1.3 to 2 times tap and is for a given measured multiple of tap.

##### Curve Characteristics

Nine inverse time functions and one fixed time function can be selected by the front-panel Curve switch. Characteristic curves for the inverse and definite time functions are defined by the following equation.

Where:

$$T_T = \frac{AD}{M^N - C} + BD + K$$

$T_T$  = time to trip in seconds  
 $D$  = time dial setting  
 $M$  = multiple of pickup setting  
 $A, B, C, N, K$  = constants for the particular curve

Time characteristic curve constants are listed in Table 6-1 and Table 6-2. Constants have been selected to conform to the characteristics of electromechanical relays over a range of pickup multiples from 1.3 to 40. Values of the constants are provided for use in computer relay setting software.

Table 6-1. Time Characteristic Curve Constants with SW3-3 Open (Off)

Curve Type *		Figure Number †	Constants					
BE1	Similar To		A	B	C	N	K	R
S	ABB CO-2	7-1	0.2663	0.03393	1.000	1.2969	0.028	0.500
L	ABB CO-5	7-2	5.6143	2.18592	1.000	1.000	0.028	15.750
D	ABB CO-6	7-3	0.4797	0.21359	1.000	1.5625	0.028	0.875
M	ABB CO-7	7-4	0.3022	0.12840	1.000	0.5000	0.028	1.750
I	ABB CO-8	7-5	8.9341	0.17966	1.000	2.0938	0.028	9.000
V	ABB CO-9	7-6	5.4678	0.10814	1.000	2.0469	0.028	5.500
E	ABB CO-11	7-7	7.7624	0.02758	1.000	2.0938	0.028	7.750
B	BS142-B ‡	7-8	1.4636	0.00000	1.000	1.0469	0.028	3.250
C	BS142-C ‡	7-9	8.2506	0.00000	1.000	2.0469	0.028	8.000
F	None §	N/A	0.0000	1.00000	0.000	0.0000	0.000	1.000

Table 6-2. Time Characteristic Curve Constants with SW3-3 Closed (On)

Curve Type *		Figure Number †	Constants					
BE1	Similar To		A	B	C	N	K	R
S	GE IAC 55	7-10	0.0286	0.0208	1.000	0.9844	0.028	0.0940
L	GE IAC 66	7-11	2.3955	0.00002	1.000	0.3125	0.028	7.8001
D	ABB CO-6	7-3	0.4797	0.21359	1.000	1.5625	0.028	0.8750
M	ABB CO-7	7-4	0.3022	0.12840	1.000	0.5000	0.028	1.7500
I	GE IAC 51	7-12	0.2747	0.1042	1.000	0.4375	0.028	0.8868
V	GE IAC 53	7-13	4.4309	0.0991	1.000	1.9531	0.028	5.8231
E	GE IAC 77	7-14	4.9883	0.0129	1.000	2.0469	0.028	4.7742
B	BS142-B ‡	7-8	1.4636	0.00000	1.000	1.0469	0.028	3.2500
C	BS142-C ‡	7-9	8.2506	0.00000	1.000	2.0469	0.028	8.0000
F	None §	N/A	0.0000	1.00000	0.000	0.0000	0.000	1.0000

## Notes for Tables 7 and 8

\* BE1 Curve Types:

S: Short Inverse	V: Very Inverse
L: Long Inverse	E: Extremely Inverse
D: Definite Time	B: BS142 Very Inverse
M: Moderately Inverse	C: BS142 Extremely Inverse
I: Inverse	F: Fixed Time Delay

† Figure numbers refer to the characteristic curves located in the *Time Characteristic Curves* chapter.

‡ Curves B and C are defined in British Standard BS142 and IEC Standard IEC 255-4.

§ Fixed time delay, adjustable from 0.1 to 9.9 seconds.

Integrating Reset

Reset begins when the current drops below 95% of pickup. Integrating reset simulates the disk reset of electromechanical relays. The BE1-50/51B-254 provides the integrating reset function even when input current falls to zero.

Integrating reset characteristics are defined by the following equation and shown in Figure 6-1. Equation constants are provided in Table 6-1 and Table 6-2.

Integrating Reset Equation:

$$T_R = \frac{RD}{M^2 - 1}$$

Where:

- T<sub>R</sub> = Time to reset in seconds
- R = Constant for the particular curve
- D = TIME DIAL setting
- M = Current in multiples of PICKUP setting during reset

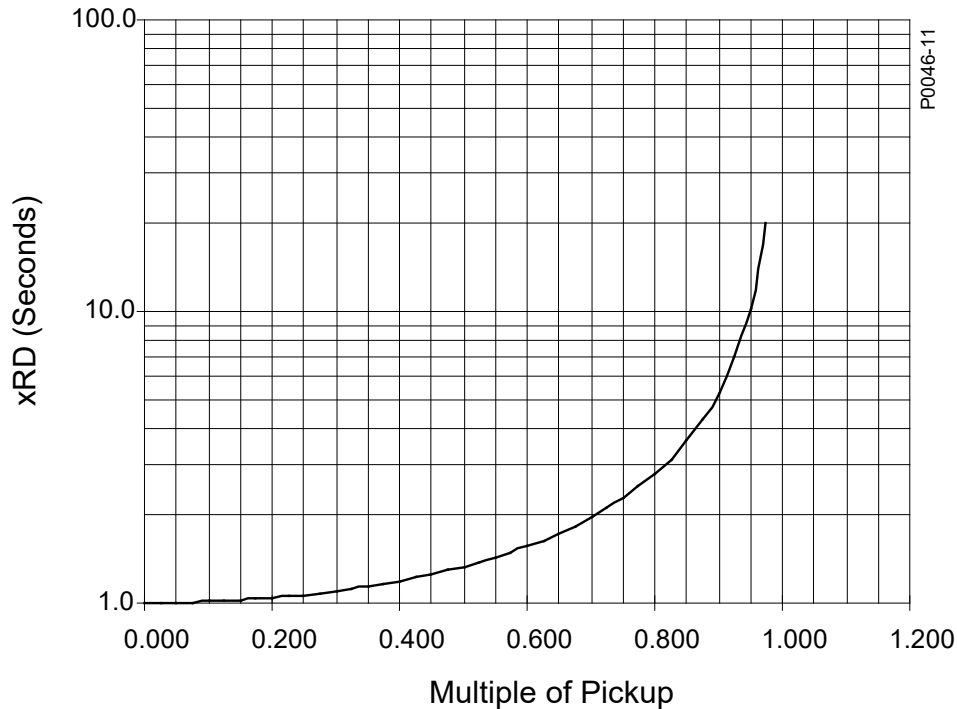

Vertical axis xRD (Seconds) is applicable for all curves and is derived from multiplying the constant R for the curve selected times D (the Time Dial setting).

Figure 6-1. Integrating Reset Characteristic Curve

### Instantaneous Overcurrent (50) Element

Setting the INST PICKUP control to the minimum pickup setting (1.0) places the relay in the most sensitive state and may be used as a safety setting.

Pickup

- Setting Range ..... 1 to 99 Aac
- Setting Increment ..... 1 Aac
- Accuracy..... ±2%, ±25 milliamperes at or above 1.0 ampere setting

Dropout

Dropout occurs at 95% of pickup value.

Curve Characteristics

Instantaneous characteristic curves are similar to standard electromechanical instantaneous units. However, the time to trip for applications where the initial current through the relay is less than 0.4 amperes may be slightly longer. This may occur on a very lightly loaded circuit or when the relay is providing ground protection and is connected to measure neutral current. Figure 6-2 shows the instantaneous characteristic curves for maximum time to trip.

An additional fixed delay of 0.1 second may be added with internal switch SW3-2. This delay applies to both phase and ground applications. Closing switch SW3-2 provides an additional delay of 0.1 second. The *Controls and Indicators* chapter illustrates the location of SW3.

The instantaneous element in BE1-50/51B-254 relays may be set lower than the instantaneous element in ABB relays and still have the same reach. This is because the BE1-50/51B-254 instantaneous element effectively eliminates the fault current transient overreach components. When calculating BE1-50/51B-254 relay instantaneous element settings, calculate the symmetrical value without any adder for transient overreach.

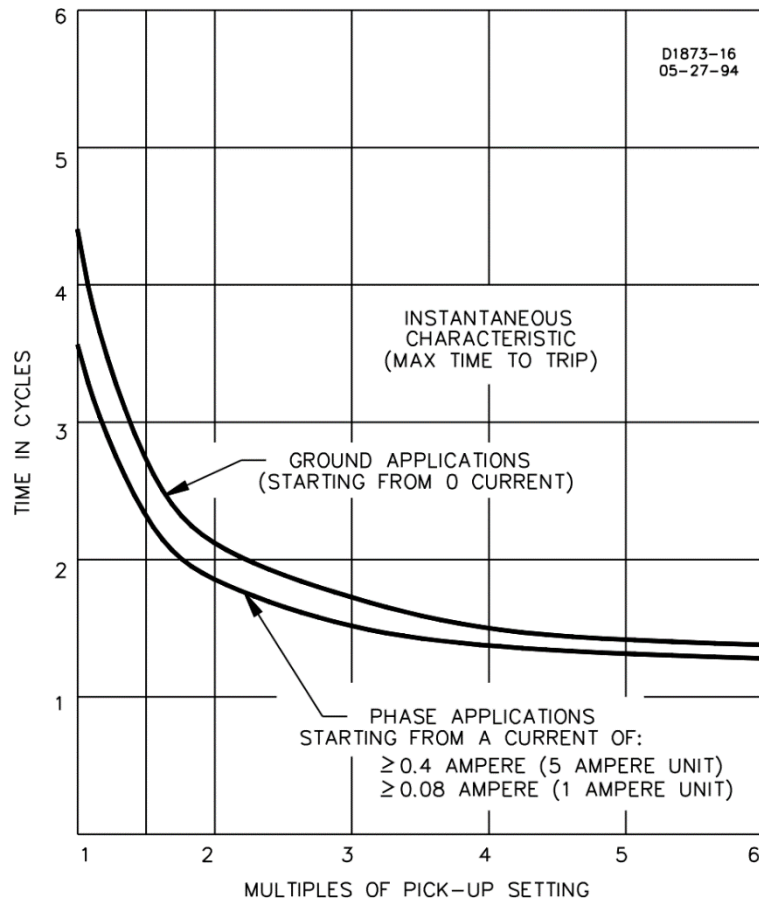

Figure 6-2. Instantaneous Characteristic Curves

## General Specifications

### Current Sensing Input

Continuous Current ..... 14 Aac  
 One Second Rating ..... 400 Aac

### Burden

Burden is non-linear. Figure 6-4 illustrates the device burden.

At 0.5 amperes .....  $Z = 4.4 \Omega$   
 At 5.0 amperes .....  $Z = 0.2 \Omega$

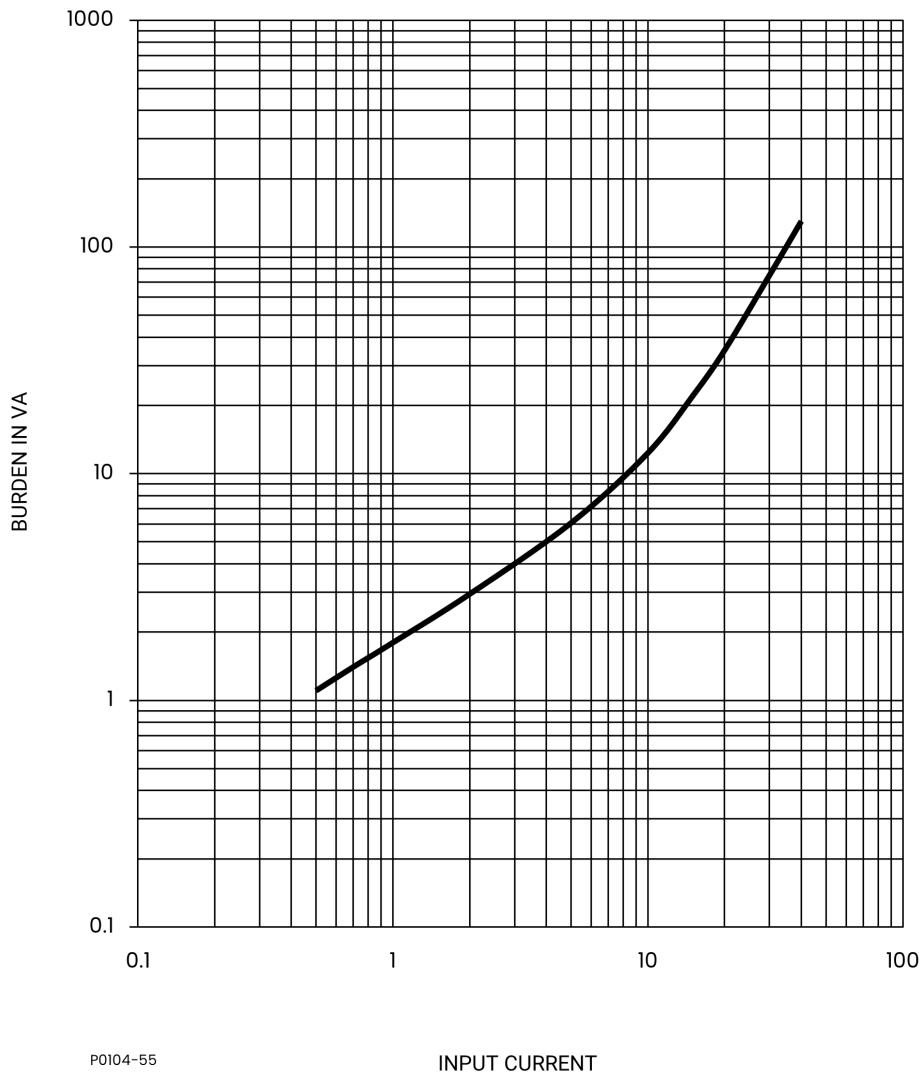

Figure 6-3. Burden Characteristics

### Frequency Response

A change of  $\pm 5$  Hz from the nominal 50/60 Hz current causes  $<0.5\%$  change in the current required for pickup.

## Transient Response

<10% overreach with system time constants up to 40 ms.

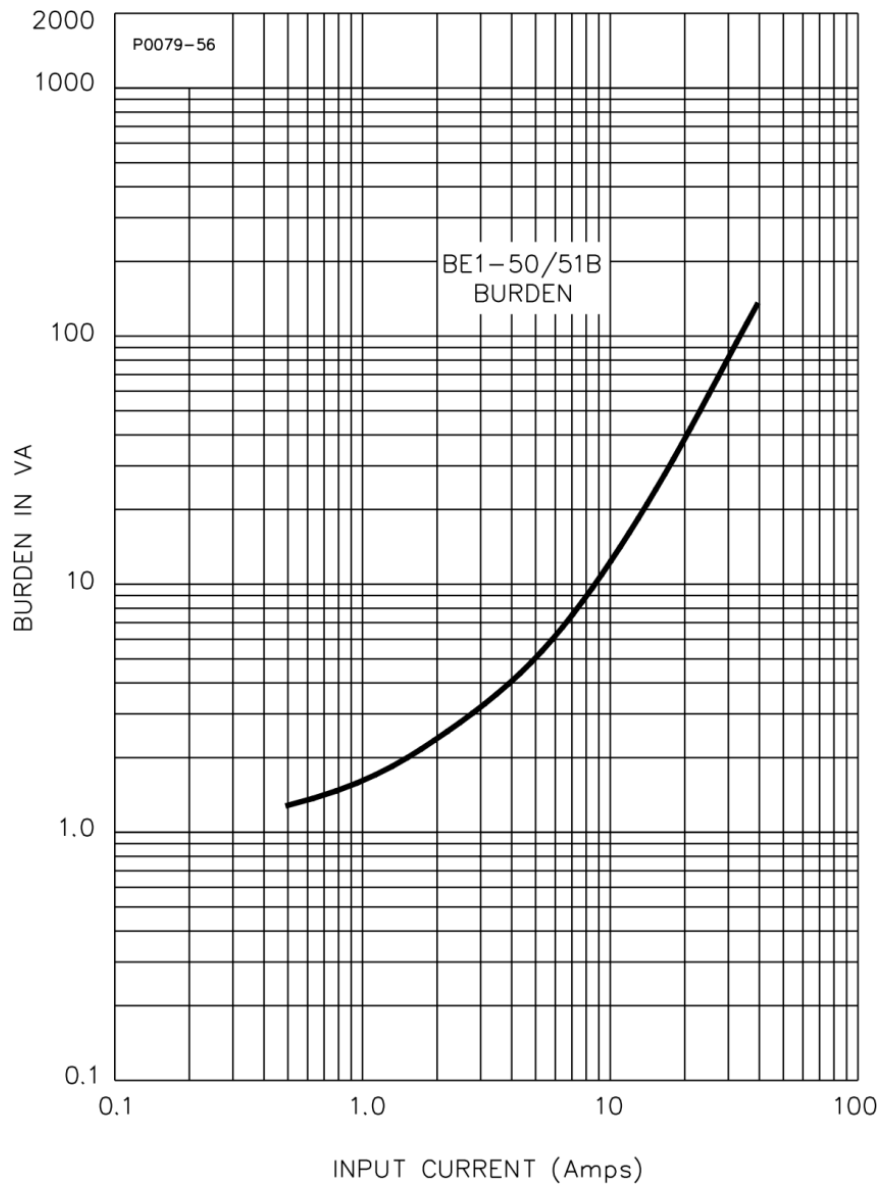

**Figure 6-4. Burden Characteristics**

### Harmonic Response

Figure 6-5 shows that a relay set for 1 ampere pickup would pick up at 0.96 amperes with a current containing 40% seventh harmonic. This corresponds to a 10:1 rejection ratio. Other conditions may be evaluated in the same manner.

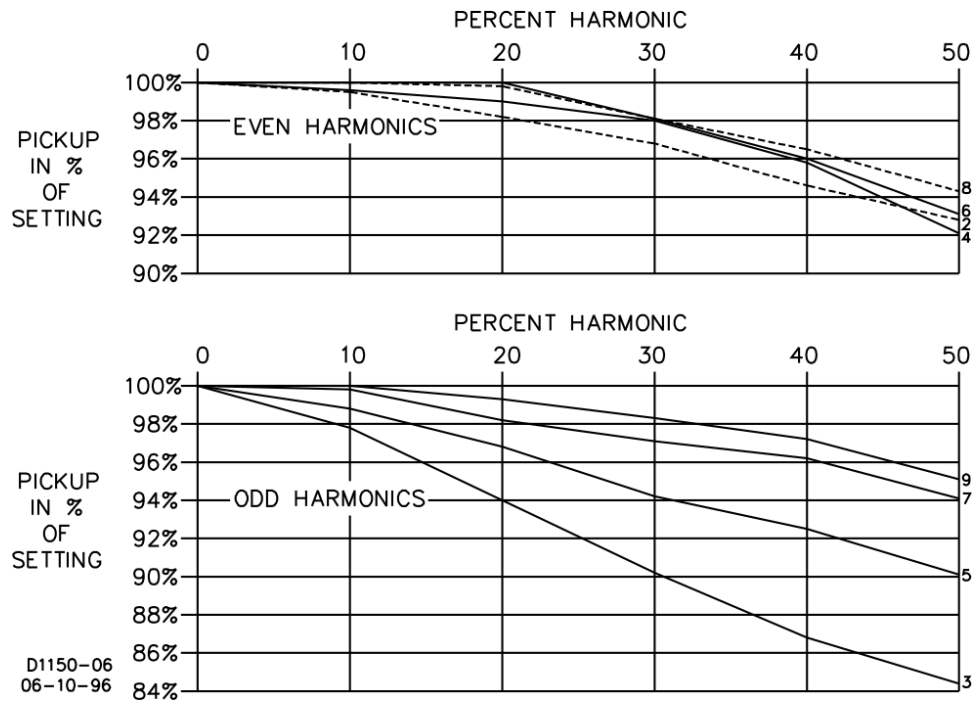

Figure 6-5. Harmonic Rejection

### Target Indicators

Gravity-latched, manually-reset targets indicate that current of 0.2 amperes or greater was present in the trip circuit. Target coil resistance is less than 0.1 ohms and operate time is less than one millisecond. See *Output Contacts* for maximum current rating. The level of trip circuit current required to operate each target is individually controlled by a circuit board jumper. See Section 2, *Controls and Indicators* for jumper locations and function assignments.

#### Target Operate Current

Jumper Position—Pins 1 and 2.....Must operate  $\geq$  2.25 A; must not operate < 900 mA. \*

Jumper Position—Pins 2 and 3.....Must operate  $\geq$  200 mA; must not operate < 80 mA. \*

\* See *Output Contacts* for the maximum acceptable levels of trip circuit currents.

### Output Contacts

Output contacts are surge protected and rated as follows:

#### Resistive Ratings

120/240 Vac .....Make 30 amperes for 0.2 seconds, carry 7 amperes for 2 minutes, 3 amperes continuously, and break 5 amperes.

125/250 Vdc .....Make 30 amperes for 0.2 seconds, carry 7 amperes for 2 minutes, 3 amperes continuously, and break 0.3 ampere.

#### Inductive Ratings

120/240 Vac, 125/250 Vdc.....Make and carry 30 amperes for 0.2 seconds, carry 7 amperes for 2 minutes, 3 amperes continuously, and break 0.3 ampere. (L/R = 0.04).

## Type Tests

Isolation .....	IEEE C37.90-2005
Transient Surge .....	IEEE C37.90.1-2004
Radiated Interference .....	IEEE C37.90.2-2004
Electrostatic Discharge .....	IEEE C37.90.3-2006
Vibration .....	IEC 255-21-1
Shock and Bump .....	IEC 255-21-2

## Environment

Operating Temperature .....	-40°C to 70°C (-40°F to 158°F)
Storage Temperature .....	-50°C to 70°C (-58°F to 158°F).

## FCC Requirements

This product complies with FCC 47 CFR Part 15.

## China RoHS

The following table serves as the declaration of hazardous substances for China in accordance with PRC standard SJ/T 11364-2014. The EFUP (Environment Friendly Use Period) for this product is 40 years.

PRODUCT: BE1-50/51B										
有害物质 Hazardous Substances										
零件名称 Part Name	铅 Lead (Pb)	汞 Mercury (Hg)	镉 Cadmium (Cd)	六价铬 Hexavalent Chromium (Cr <sup>6+</sup> )	多溴联苯 Polybrominated Biphenyls (PBB)	多溴二苯醚 Polybrominated Diphenyl Ethers (PBDE)	邻苯二甲 酸二丁酯 Dibutyl Phthalate (DBP)	邻苯二甲 酸丁苄酯 Benzyl butyl phthalate (BBP)	邻苯二甲 酸二酯 Bis(2- ethylhexyl) phthalate (BEHP)	邻苯二甲 酸二异丁 酯 Diisobutyl phthalate (DIBP)
金属零件 Metal parts	X	O	X	O	O	O	O	O	O	O
聚合物 Polymers	O	O	O	O	O	X	O	O	O	O
电子产品 Electronics	X	O	X	O	O	O	O	O	O	O
电缆和互连 配件 Cables & interconnect accessories	X	O	O	O	O	O	O	O	O	O
绝缘材料 Insulation material	O	O	O	O	O	O	O	O	O	O

本表格依据 SJ/T11364 的规定编制。

O: 表示该有害物质在该部件所有均质材料中的含量均在 GB/T 26572 规定的限量要求以下。

X: 表示该有害物质至少在该部件的某一均质材料中的含量超出 GB/T 26572 规定的限量要求。

This form was prepared according to the provisions of standard SJ/T11364.

O: Indicates that the hazardous substance content in all homogenous materials of this part is below the limit specified in standard GB/T 26252.

X: Indicates that the hazardous substance content in at least one of the homogenous materials of this part exceeds the limit specified in standard GB/T 26572.

## Physical

Weight ..... 6.1 lb (2.77 kg)

# 7 • Time Characteristic Curves

Figures 7-1 through 7-15 illustrate the characteristic curves that are programmed into the nonvolatile memory of the BE1-50/51B-254.

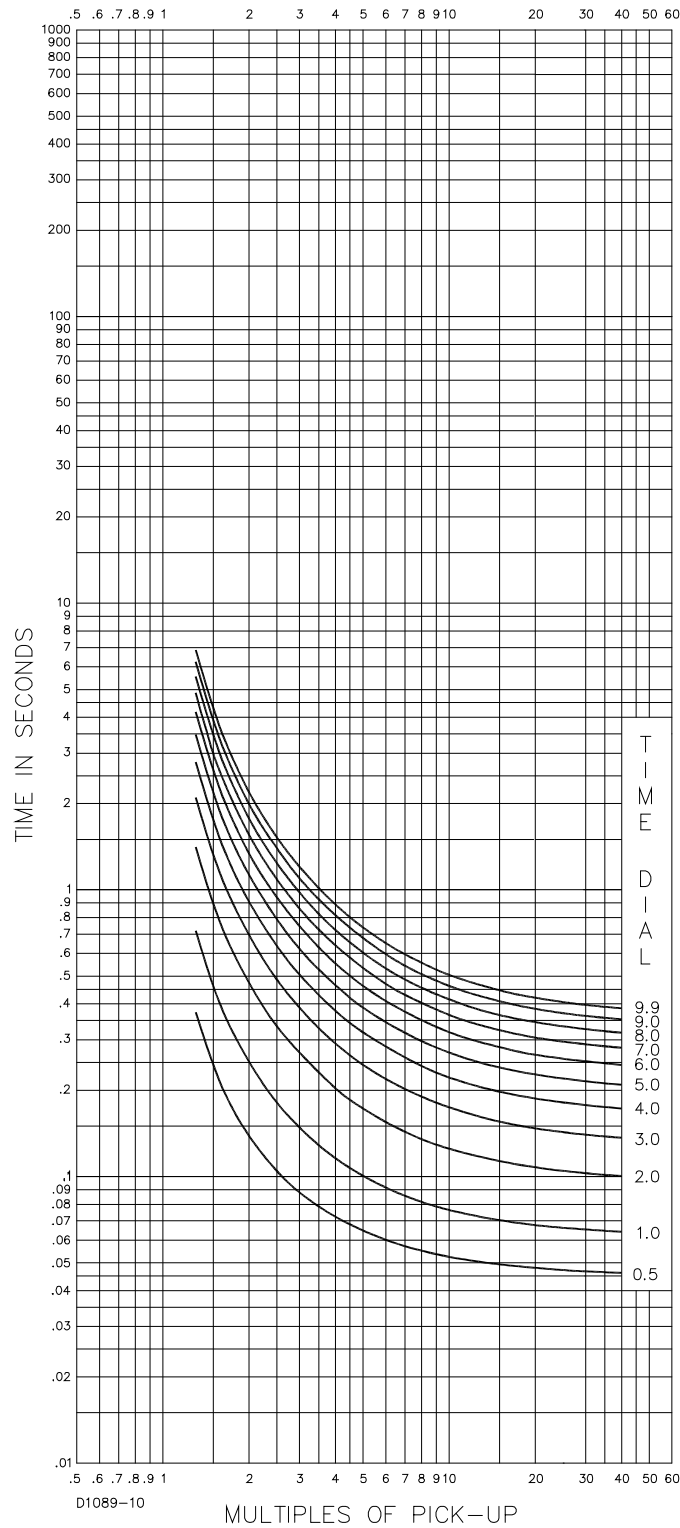

Figure 7-1. Time Characteristic Curve, S-Short Inverse (SW3-3 OFF, Similar to ABB CO-2)

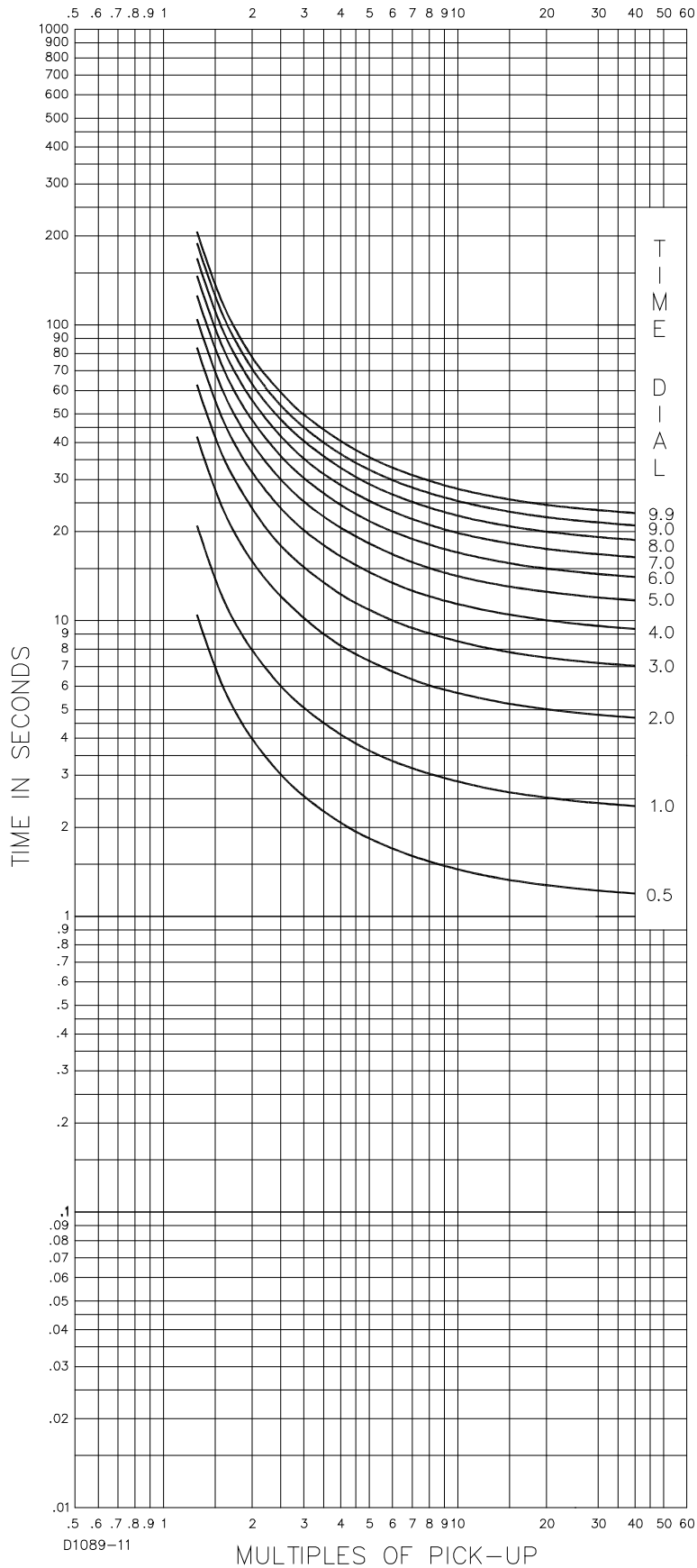

Figure 7-2. Time Characteristic Curve, L-Long Inverse (SW3-3 OFF, Similar to ABB CO-5)

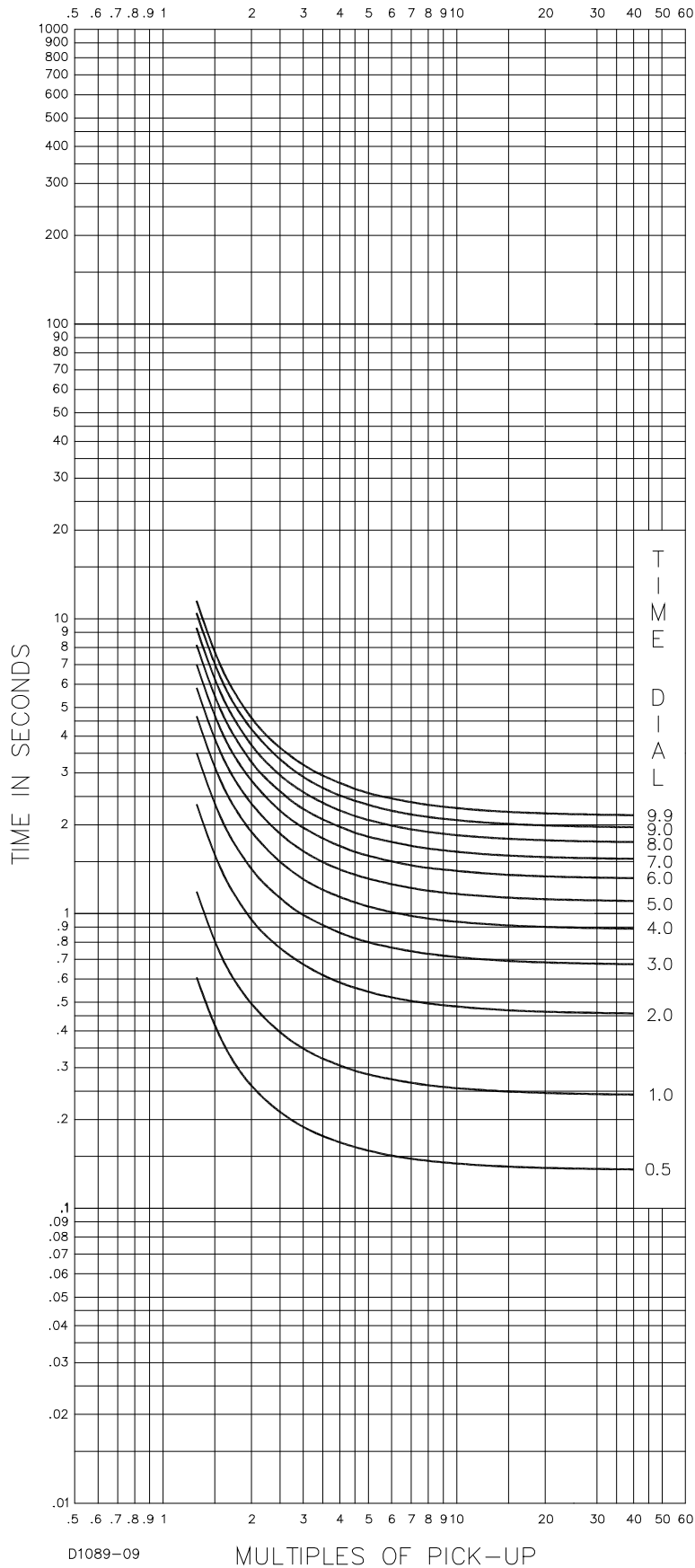

Figure 7-3. Time Characteristic Curve, D-Definite Time (Similar to ABB CO-6)

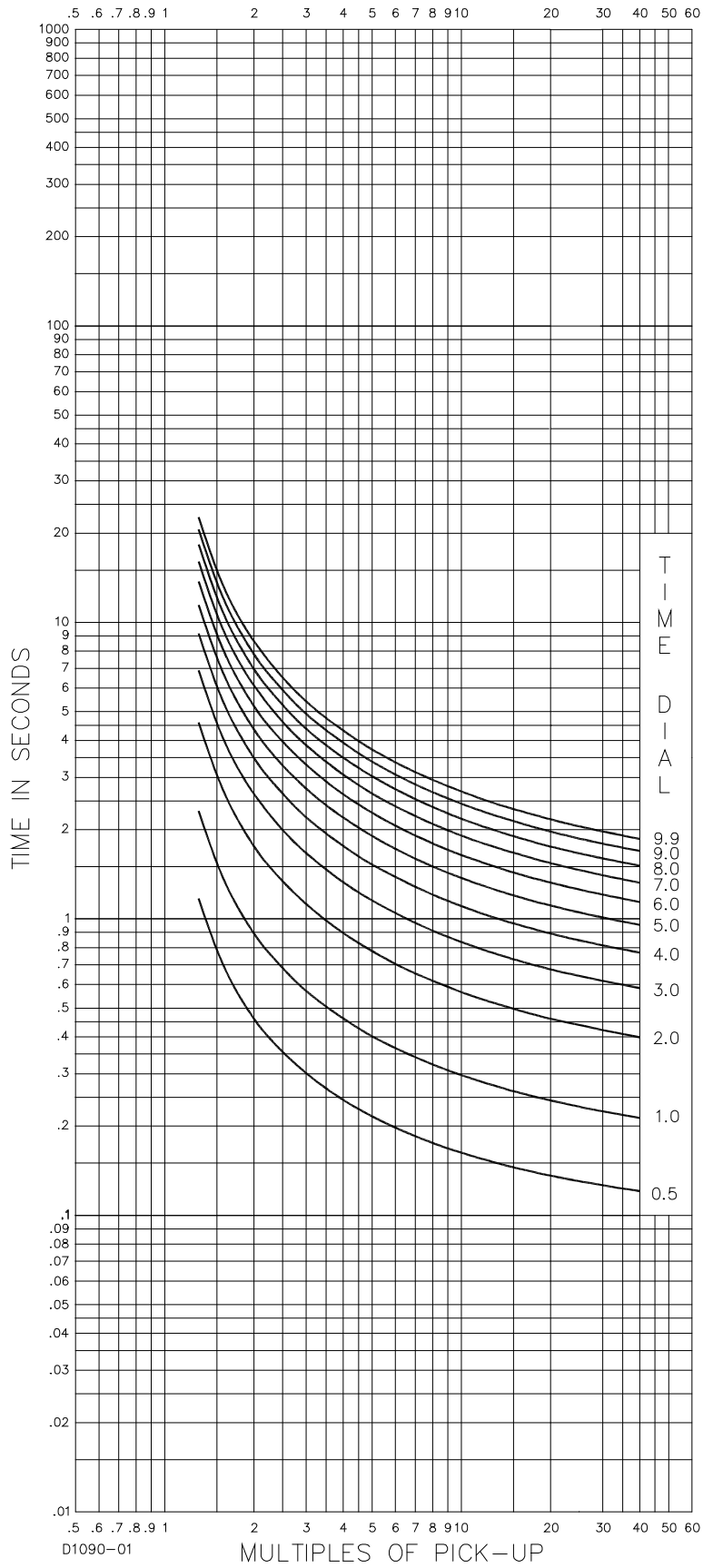

Figure 7-4. Time Characteristic Curve, M-Moderately Inverse (Similar to ABB CO-7)

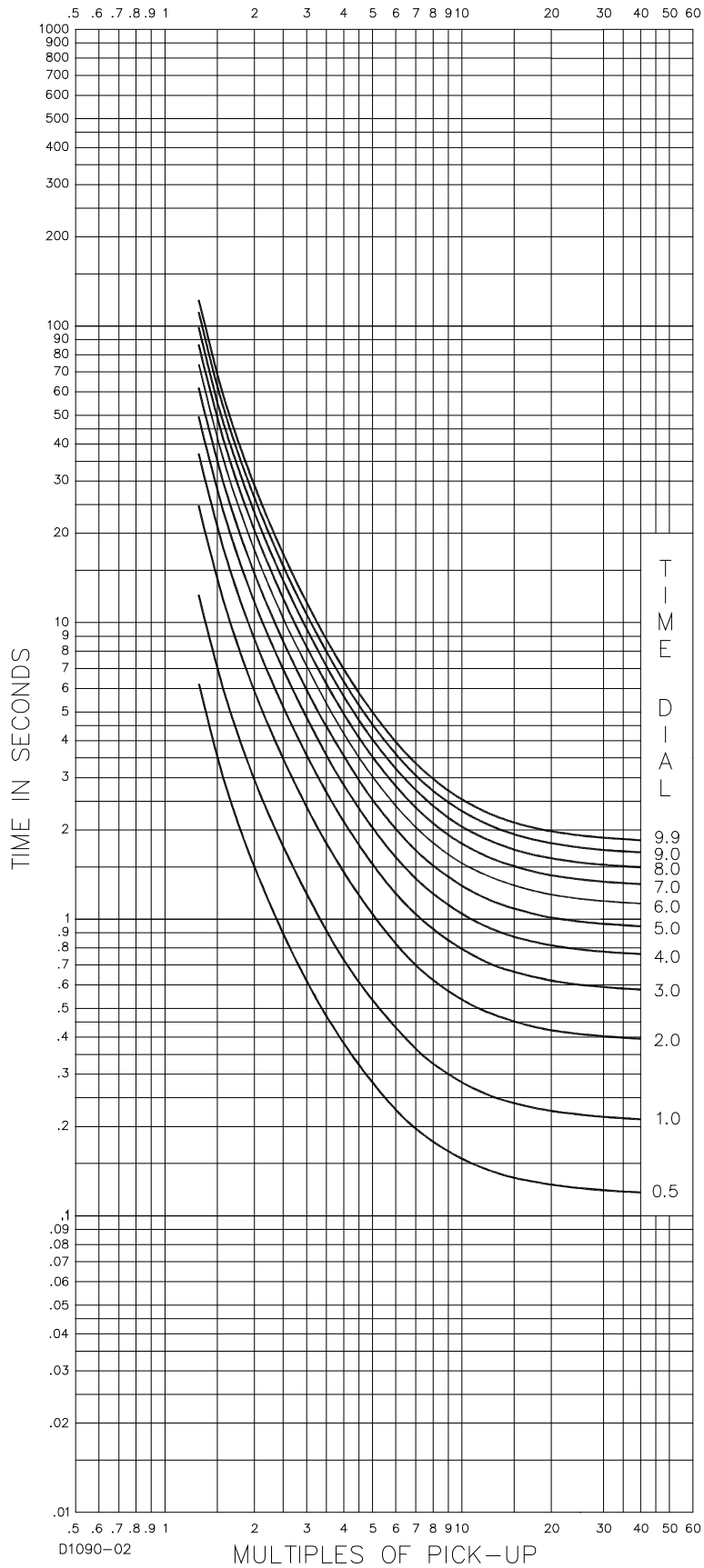

Figure 7-5. Time Characteristic Curve, I-Inverse (SW3-3 OFF, Similar to ABB CO-8)

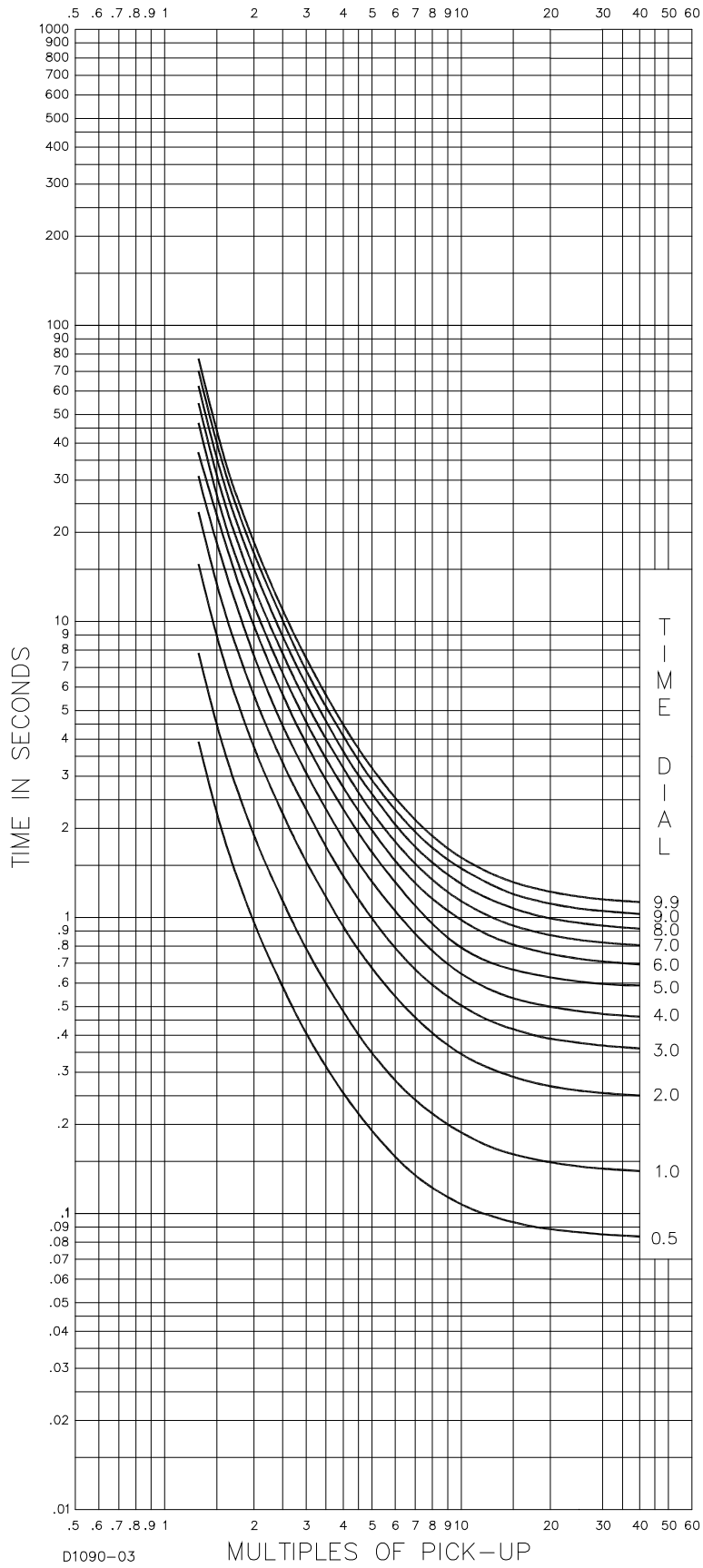

Figure 7-6. Time Characteristic Curve, V-Very Inverse (SW3-3 OFF, Similar to ABB CO-9)

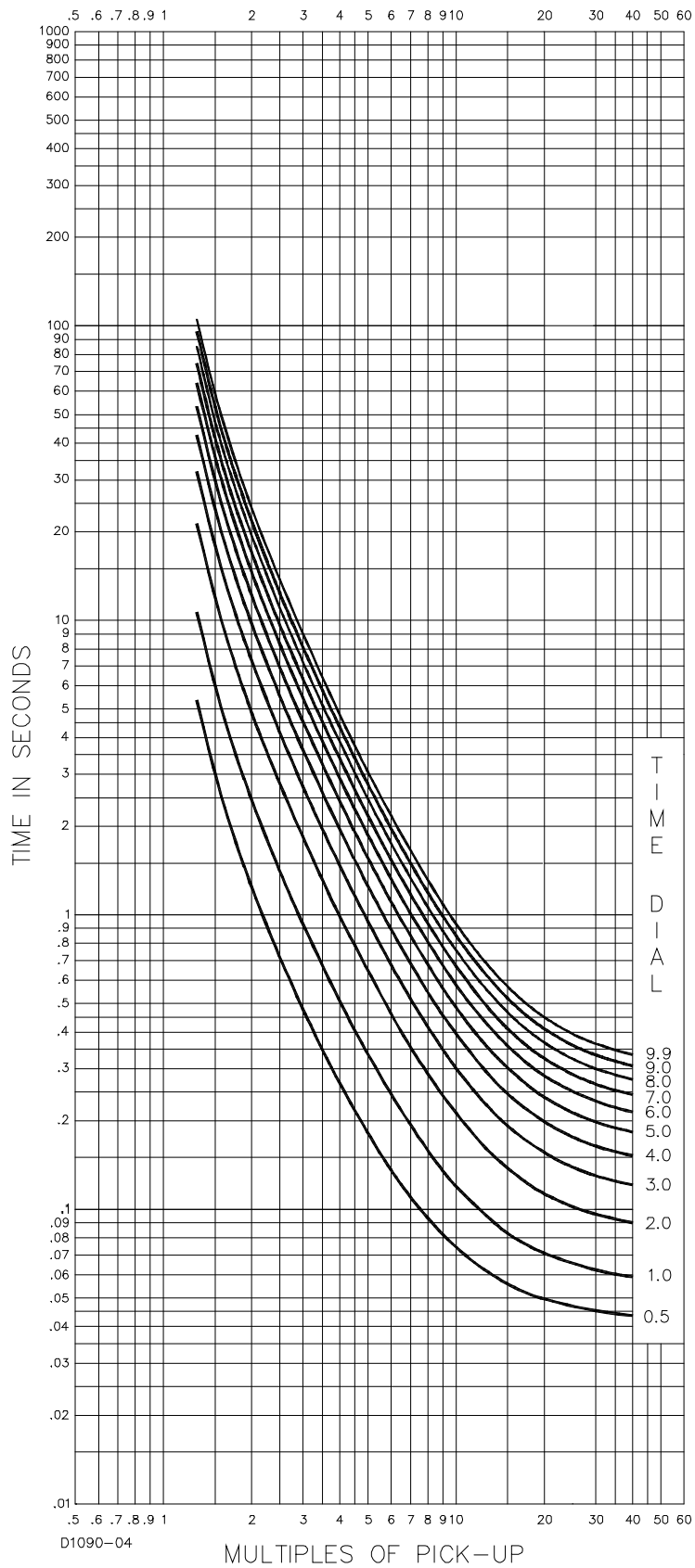

Figure 7-7. Time Characteristic Curve, E-Extremely Inverse (SW3-3 OFF, Similar to ABB CO-11)

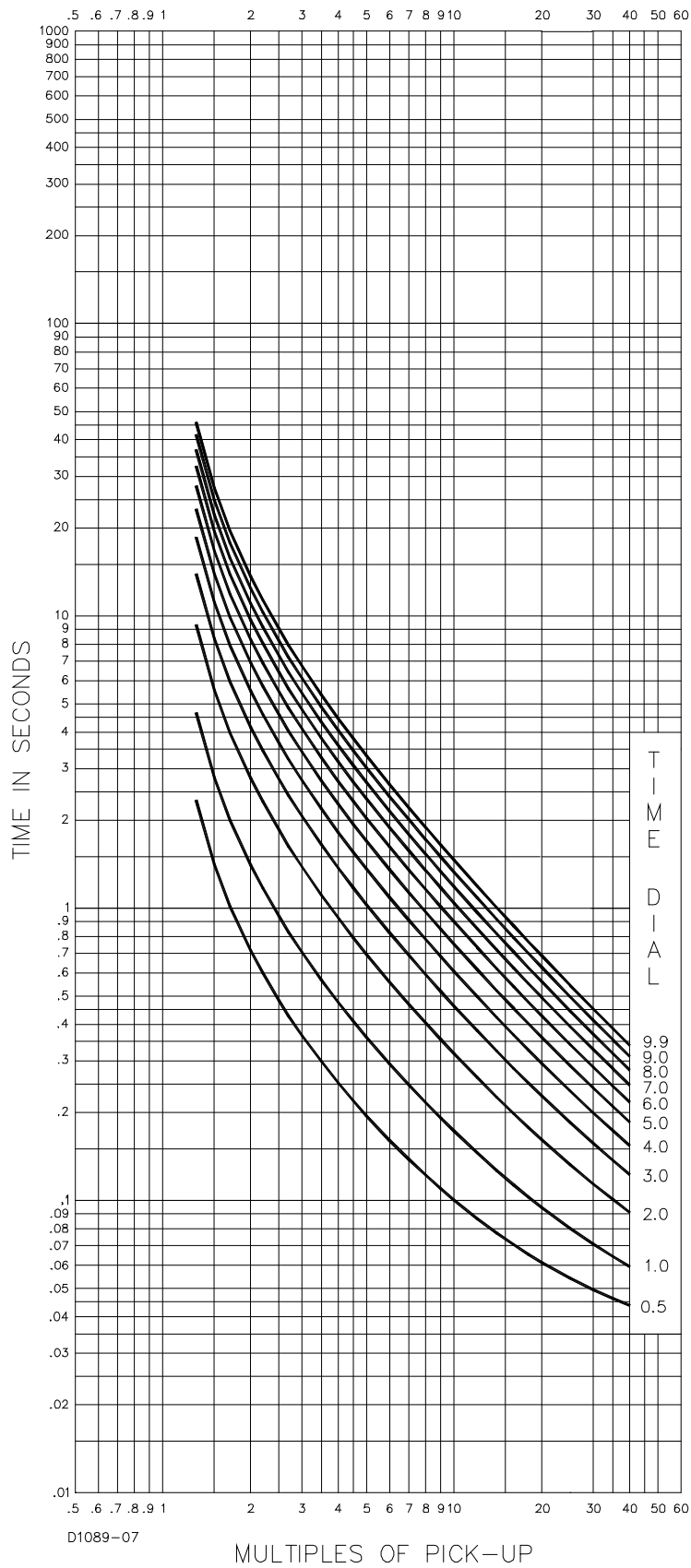

Figure 7-8. Time Characteristic Curve, BS142-B (BS142 Very Inverse)

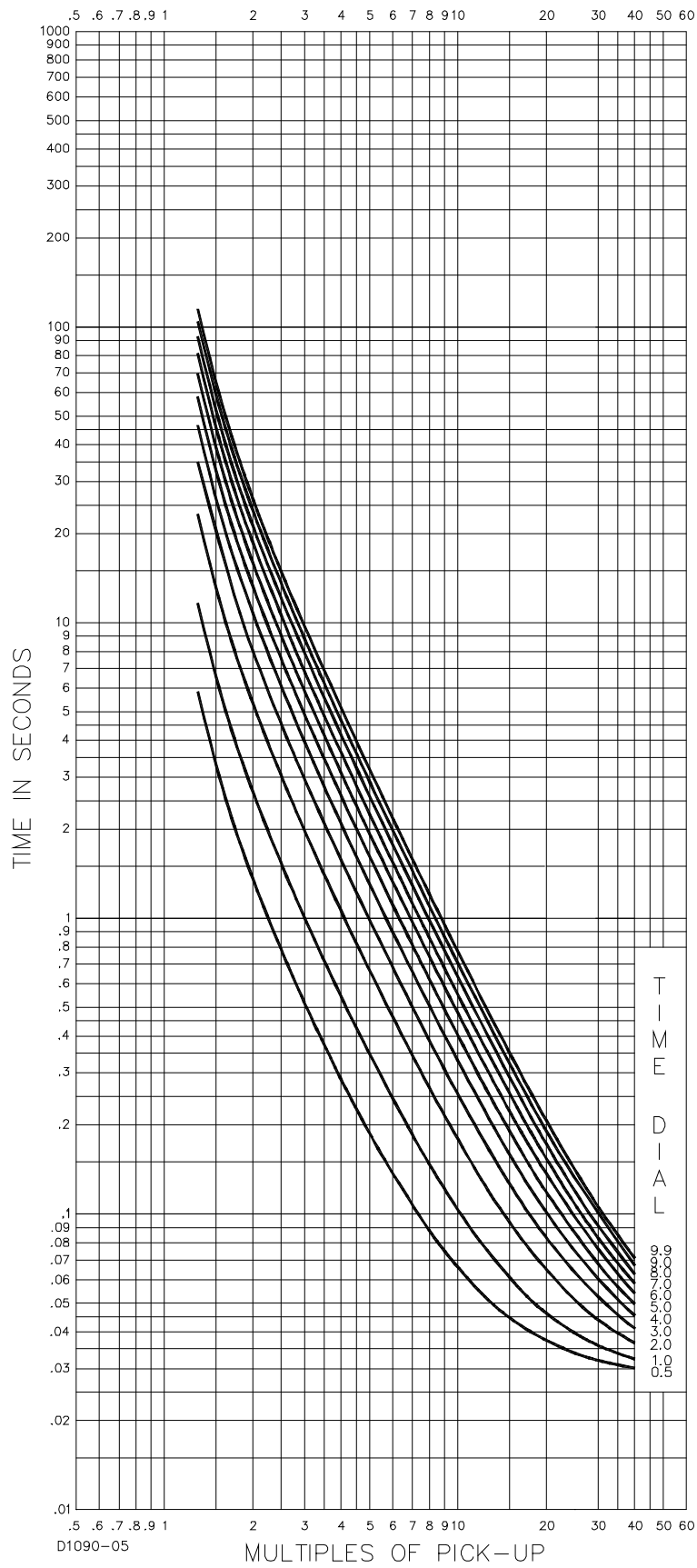

Figure 7-9. Time Characteristic Curve, BS142-C (BS142 Extremely Inverse)

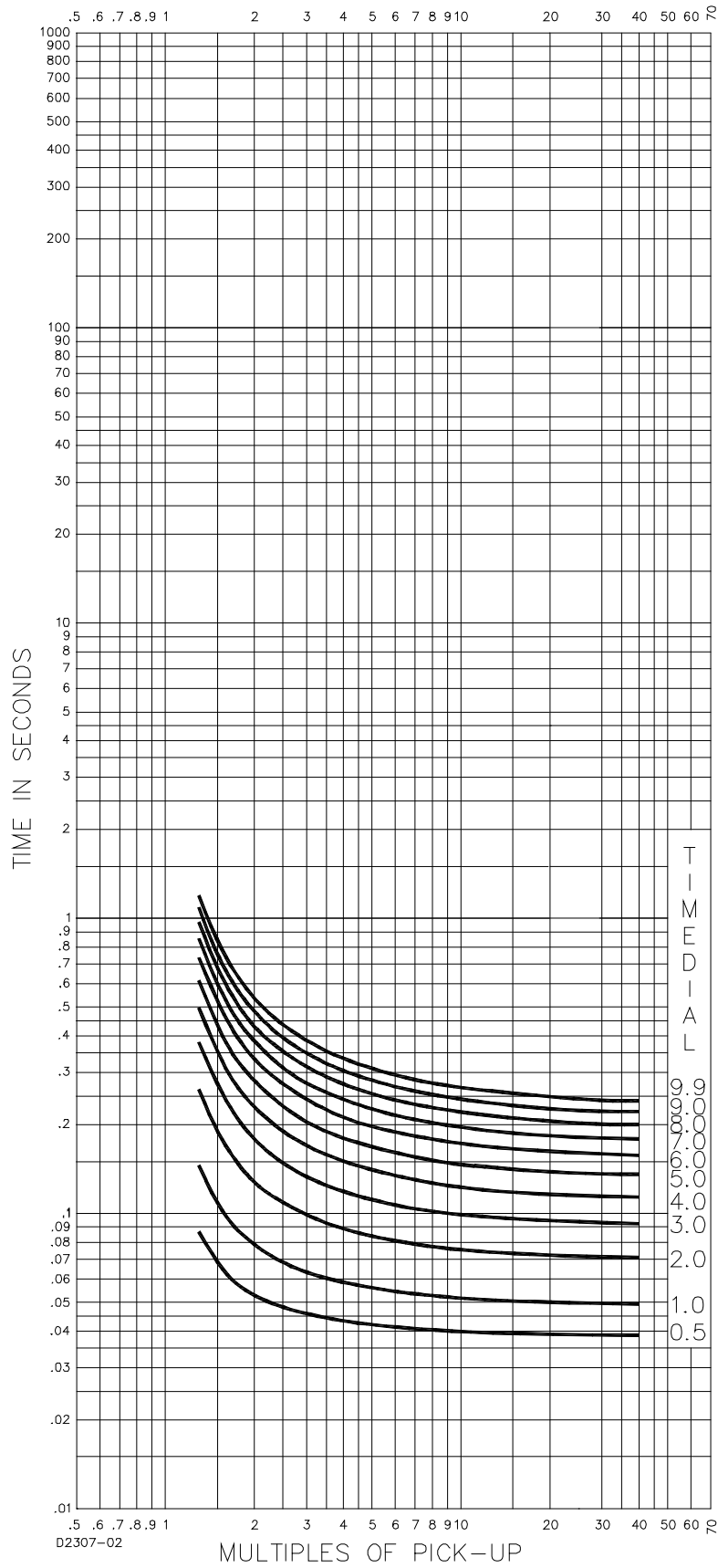

Figure 7-10. Time Characteristic Curve, S2-Short Inverse (SW3-3 ON, Similar to GE IAC 55)

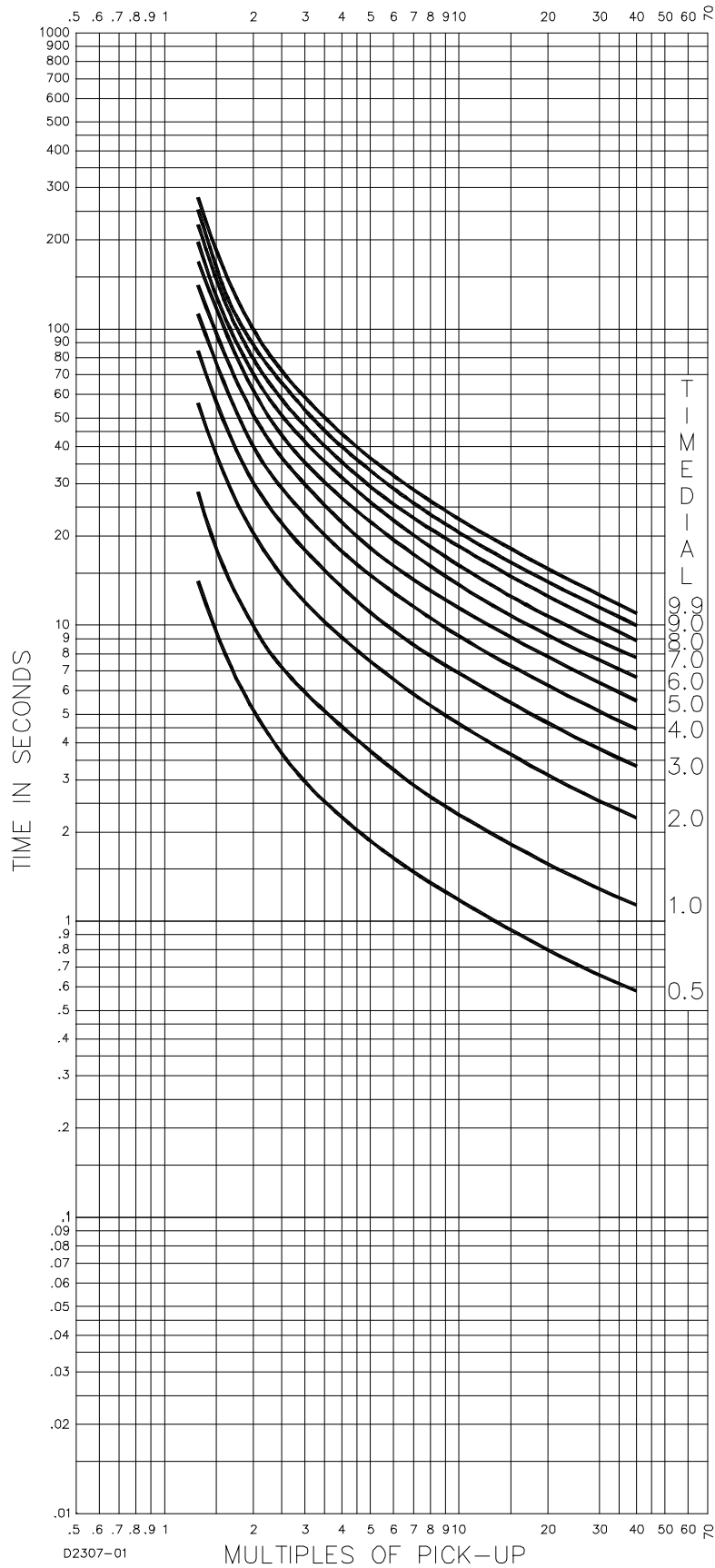

Figure 7-11. Time Characteristic Curve, L2-Long Inverse (SW3-3 ON, Similar to GE IAC 66)

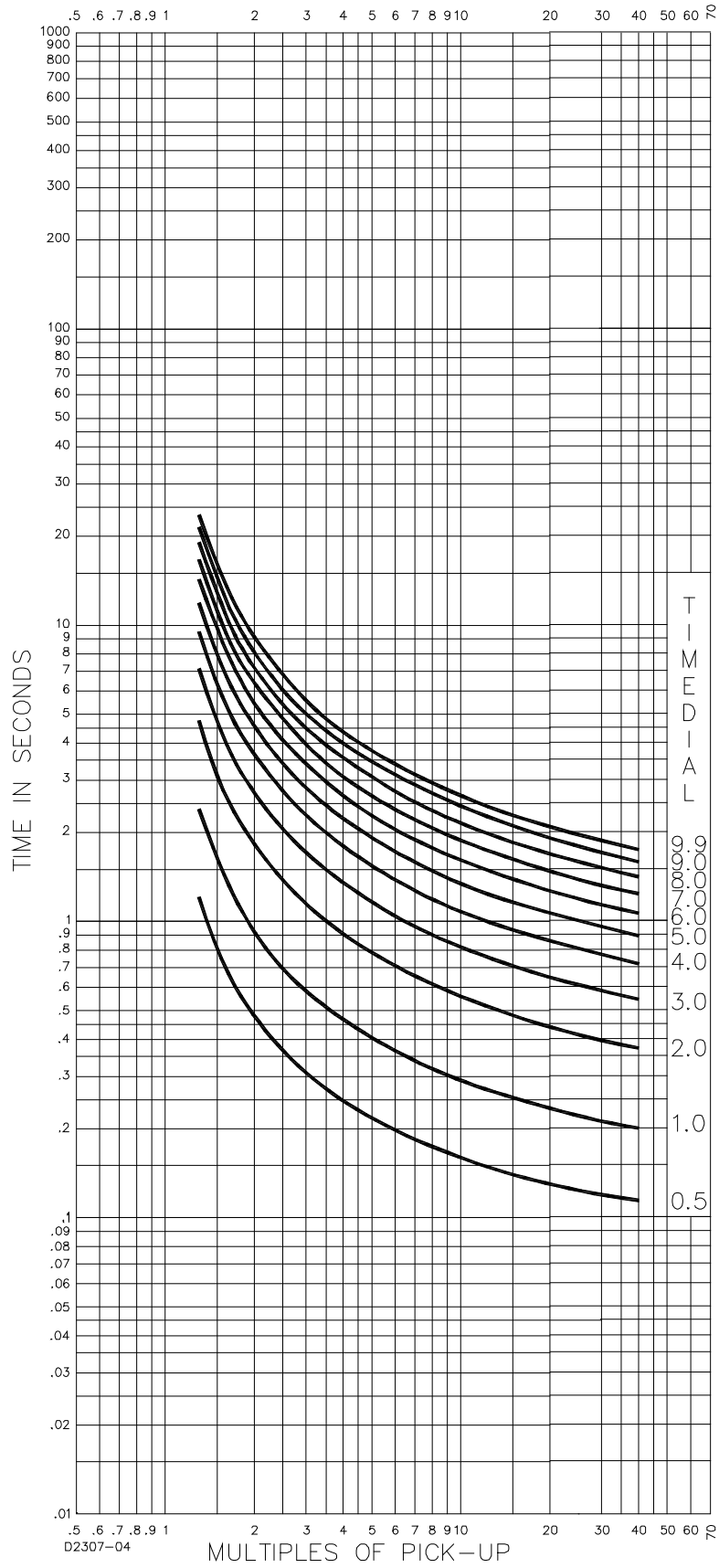

Figure 7-12. Time Characteristic Curve, I2-Inverse (SW3-3 ON, Similar to GE IAC 51)

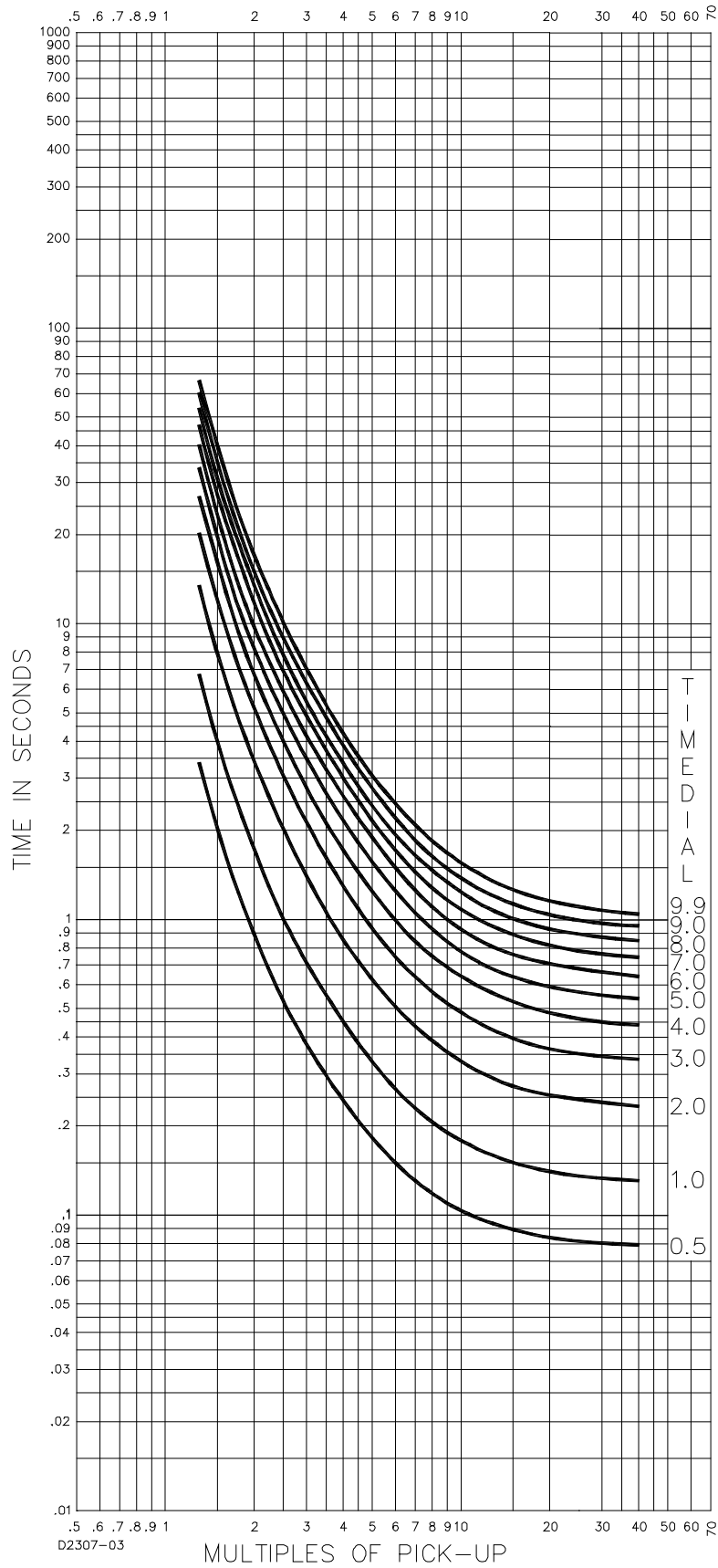

Figure 7-13. Time Characteristic Curve, V2-Very Inverse (SW3-3 ON, Similar to GE IAC 53)

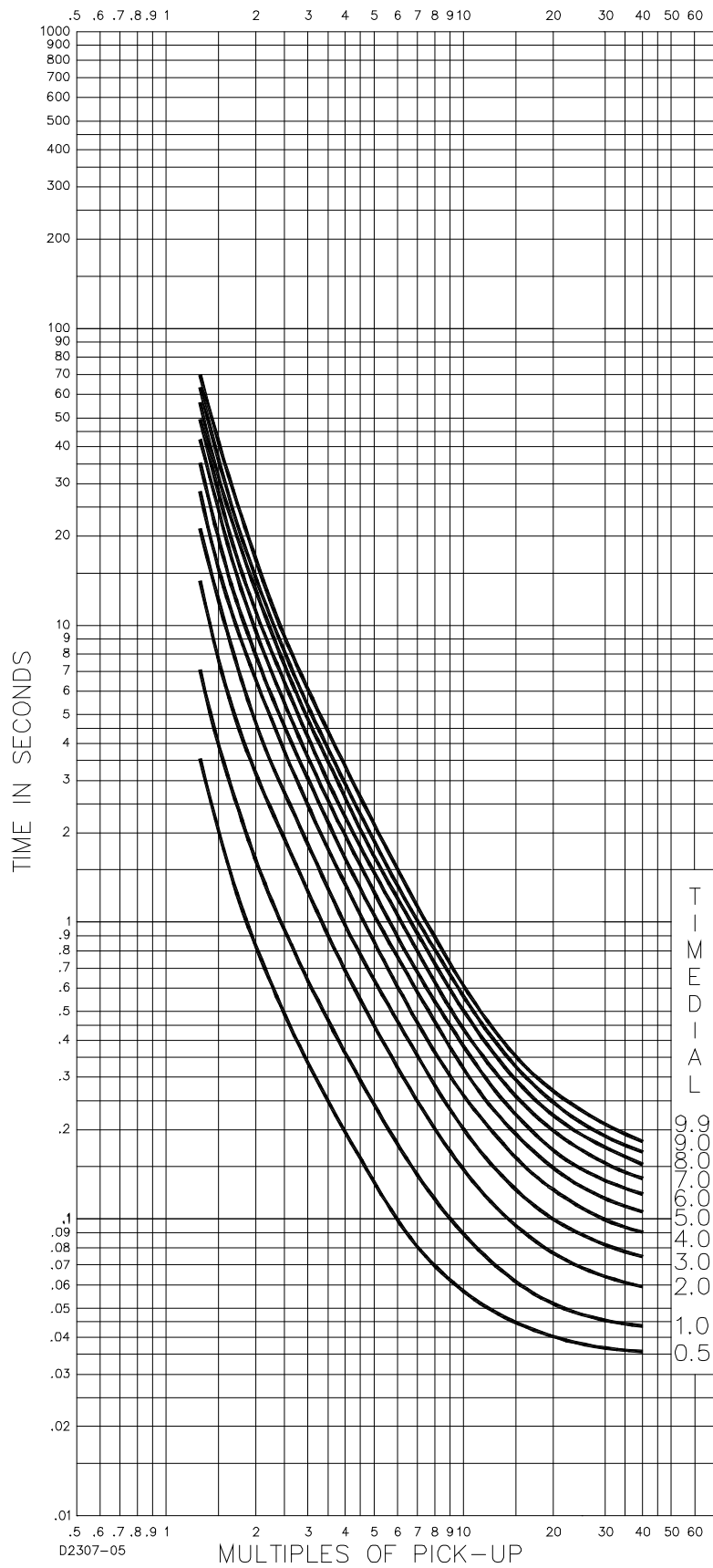

Figure 7-14. Time Characteristic Curve, E2-Extremely Inverse (SW3-3 ON, Similar to GE IAC 77)





Highland, Illinois USA  
Tel: +1 618.654.2341  
Fax: +1 618.654.2351  
email: [info@basler.com](mailto:info@basler.com)

Suzhou, P.R. China  
Tel: +86 512.8227.2888  
Fax: +86 512.8227.2887  
email: [chinainfo@basler.com](mailto:chinainfo@basler.com)